

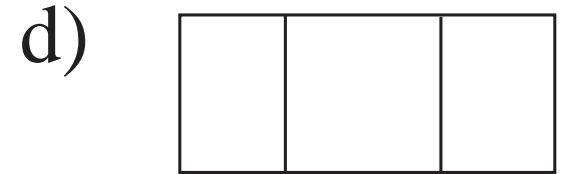

On map	In real life
1 cm	10 m
7 cm	
1 mm	
10 cm	
37 cm	
	80 m
	150 m
	5 m

On map	In real life
1 cm	500 m
1 mm	
1 cm 5 mm	
3 cm	
3 mm	
	2 km 500 m
	5 km
	400 m

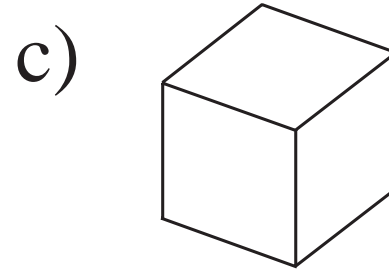
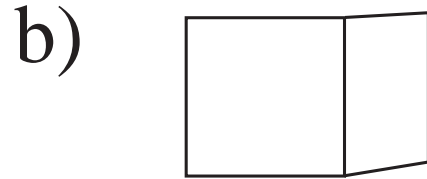
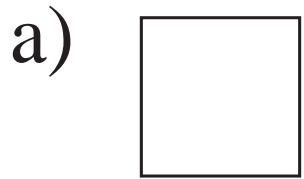

Visible			Not visible		
edges	faces	vertices	edges	faces	vertices
a)					
b)					
c)					

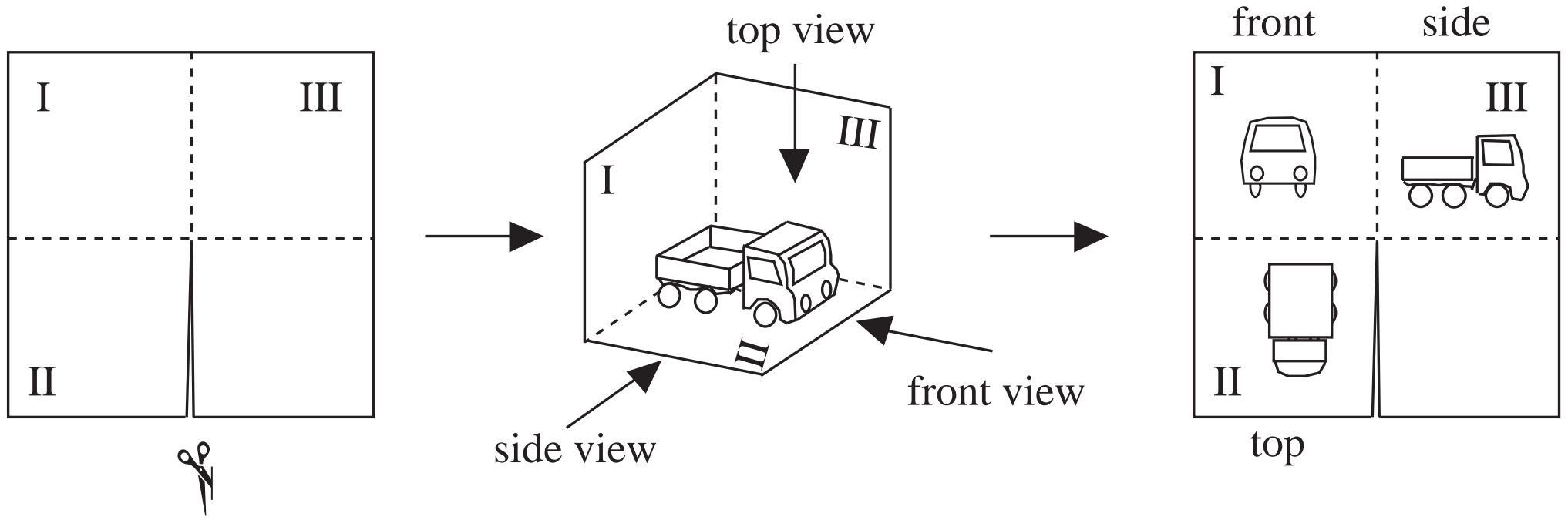

LP 51/5

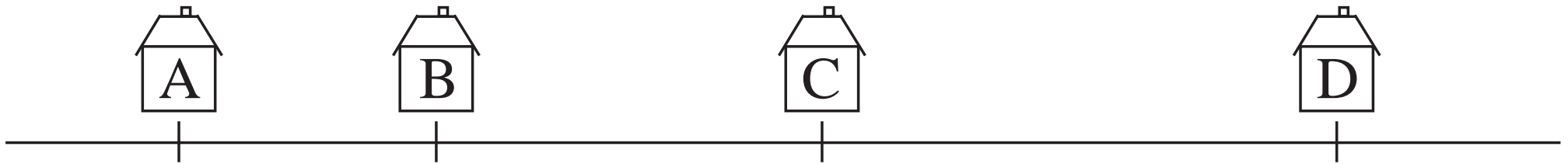

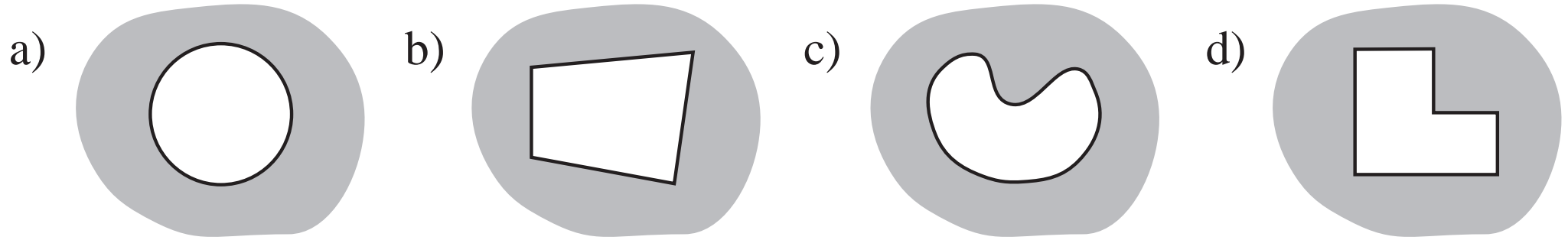

LP 51/7

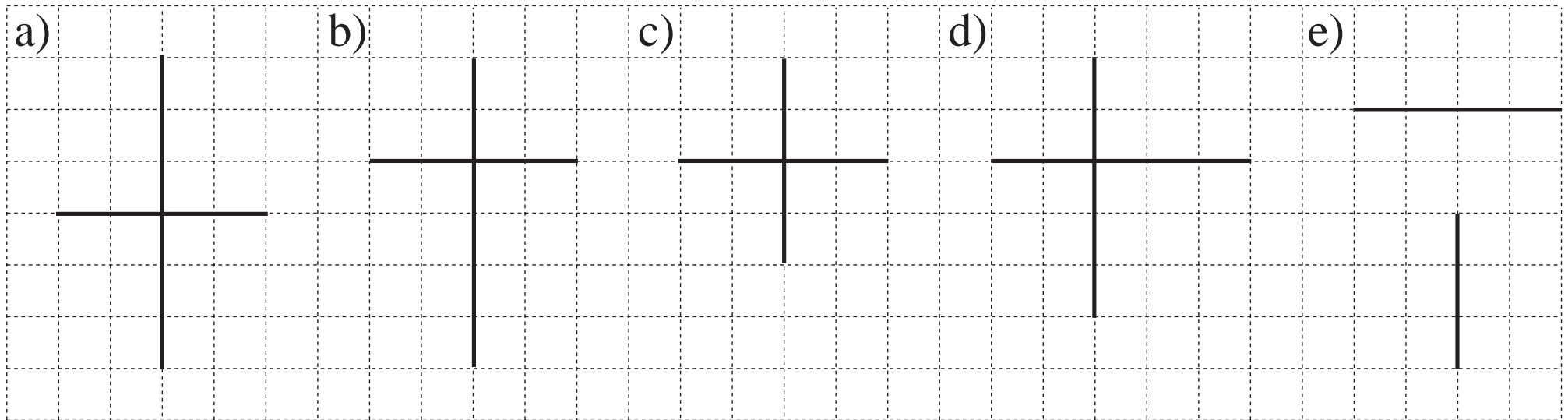

LP 51/8

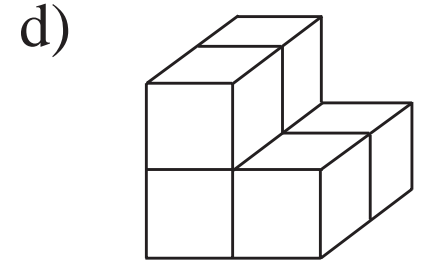
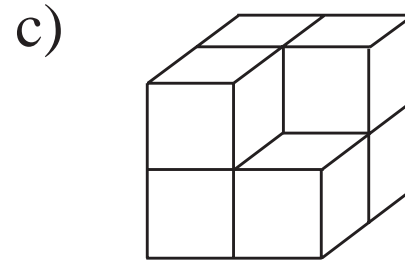
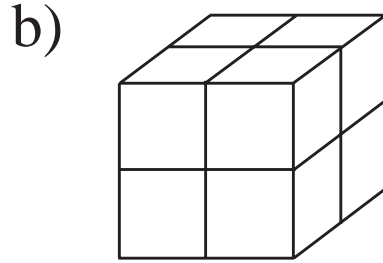
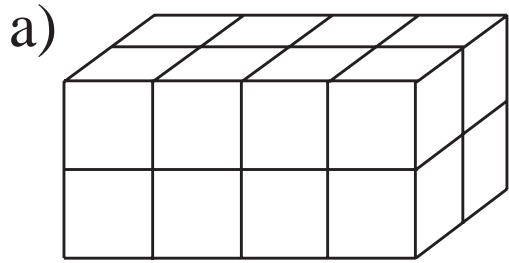

faces:

faces:

faces:

faces:

edges:

edges:

edges:

edges:

vertices:

vertices:

vertices:

vertices:

volume:

volume:

volume:

volume:

area:

area:

area:

area:

a) 1 litre = cl = ml 4000 ml = cl = litres
 14 litres = cl = ml 8500 ml = cl = litres

b) 1 kg = g 7000 g = kg
 $3\frac{1}{2}$ kg = g 4300 g = kg g

c) 1 m = cm = mm 1 km = m
 7 m = cm = mm 6 km = m
 2000 m = km 3800 m = km m

i)

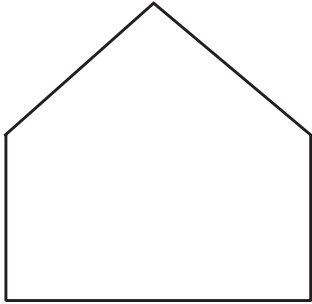

ii)

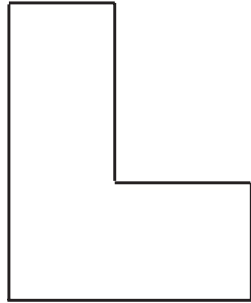

iii)

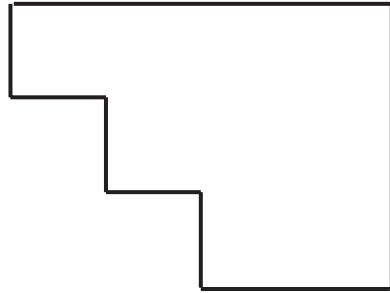

iv)

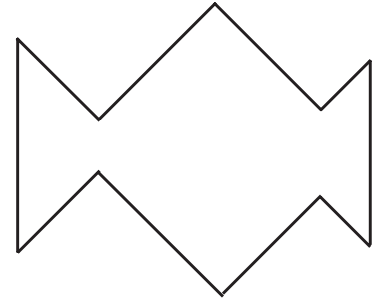

LP 52/5a

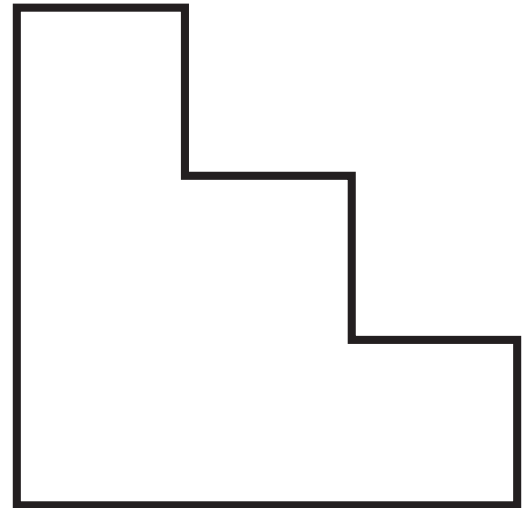
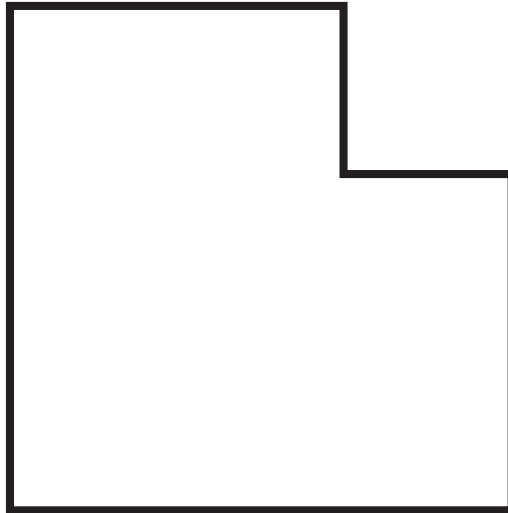
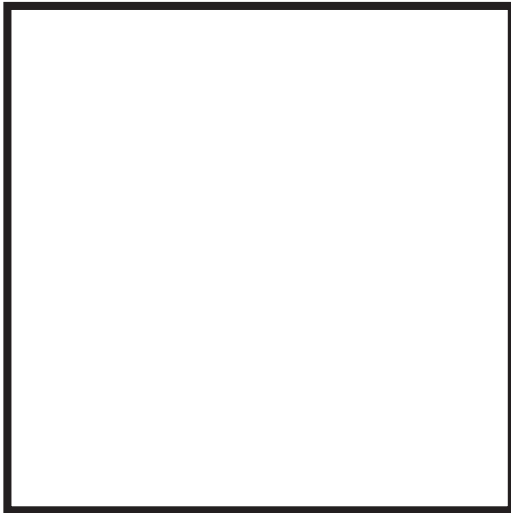

LP 52/5b

a) i)

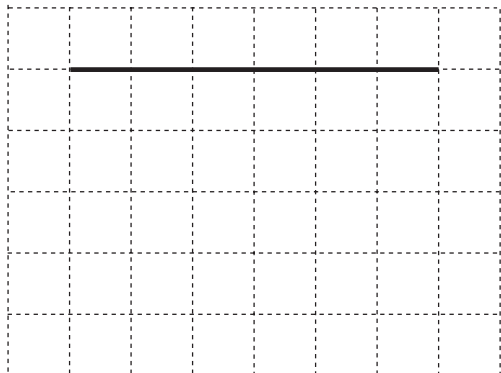

ii)

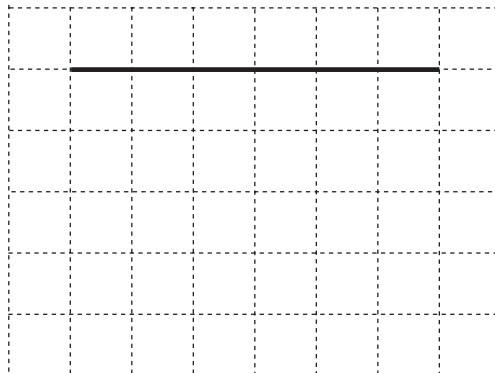

iii)

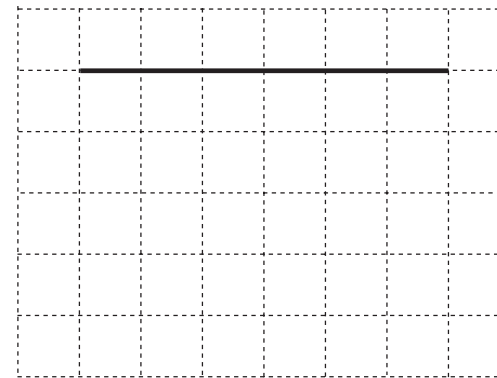

b) i)

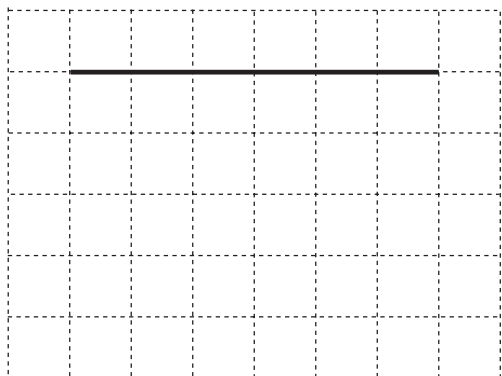

ii)

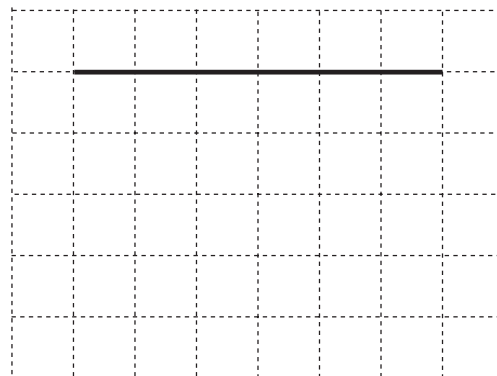

iii)

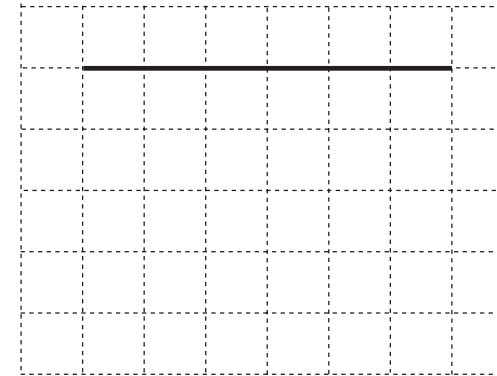

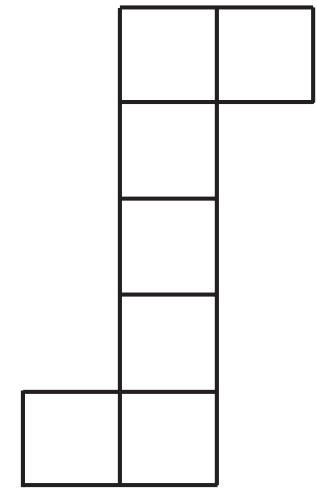

a)

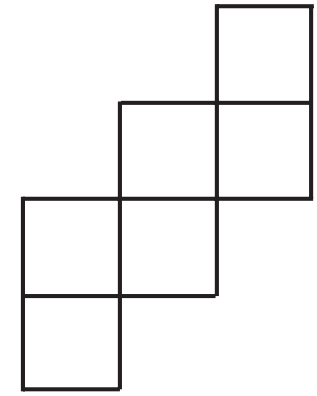

b)

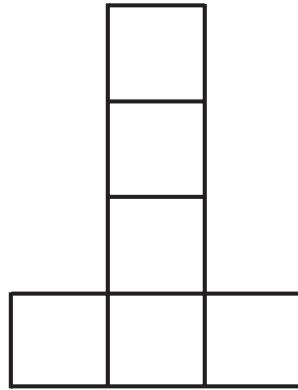

c)

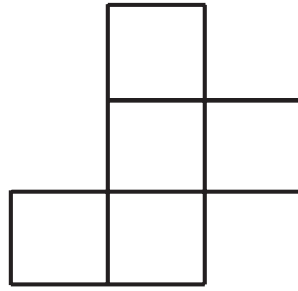

d)

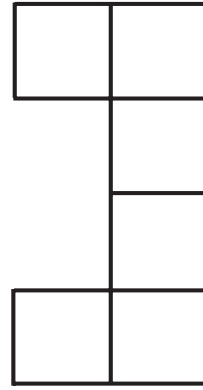

e)

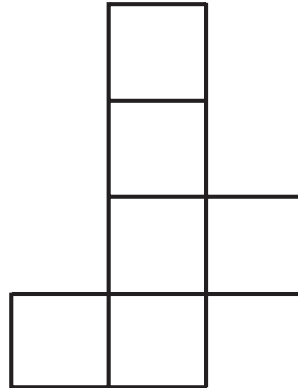

f)

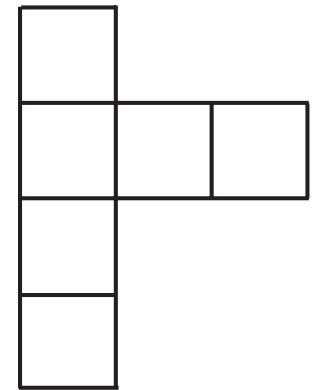

g)

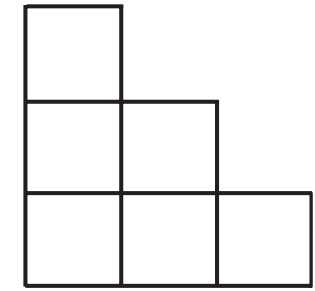

h)

a)

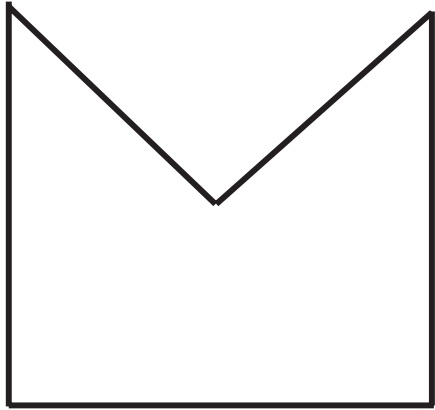

b)

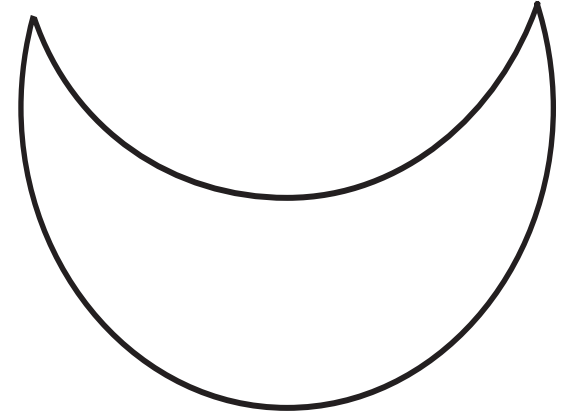

c)

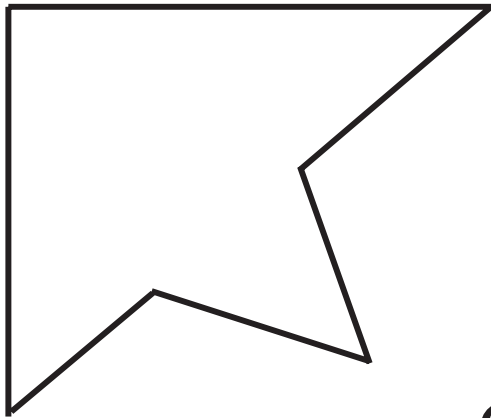

d)

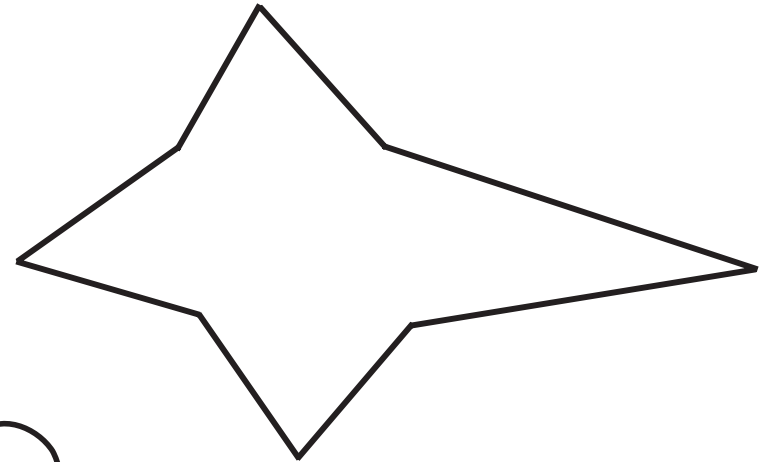

e)

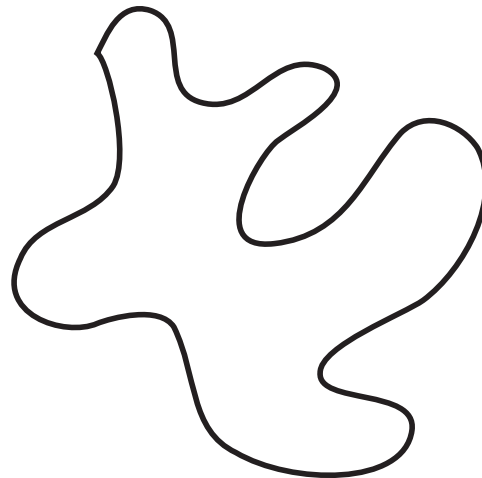

In real life

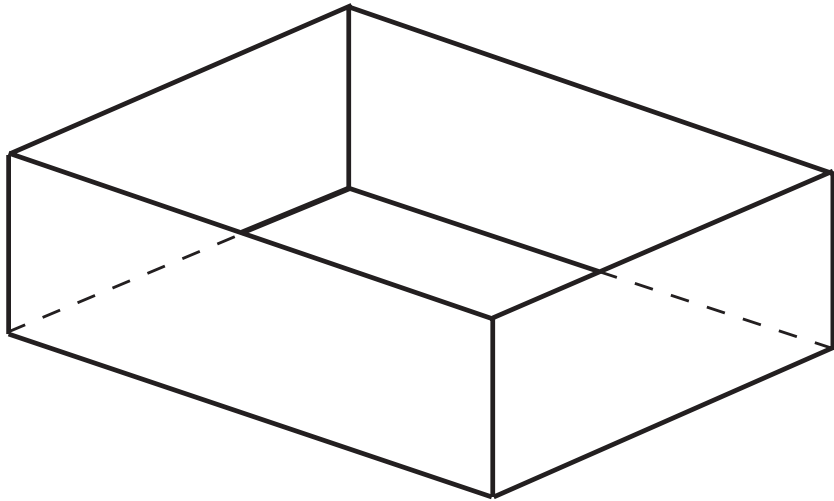

1 fifth of the size

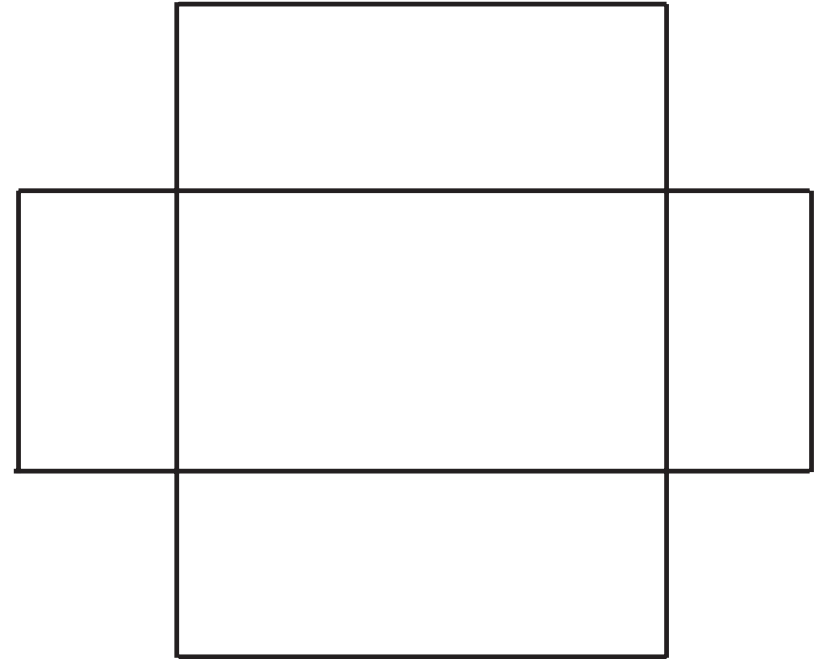

a) $5 \text{ km } 320 \text{ m}$ $4100 \text{ m} + 1 \text{ km } 140 \text{ m}$

b) 3924 ml $2 \text{ litres } 2131 \text{ ml}$

c) $75 \text{ m } 27 \text{ cm}$ $4010 \text{ cm} + 3 \text{ m } 80 \text{ cm}$

d) $8300 \text{ g} - 2 \text{ kg } 400 \text{ g}$ $5 \text{ kg } 900 \text{ g}$

e) $7 \text{ hours } 14 \text{ minutes}$ $1000 \text{ minutes} - 9 \text{ hours}$

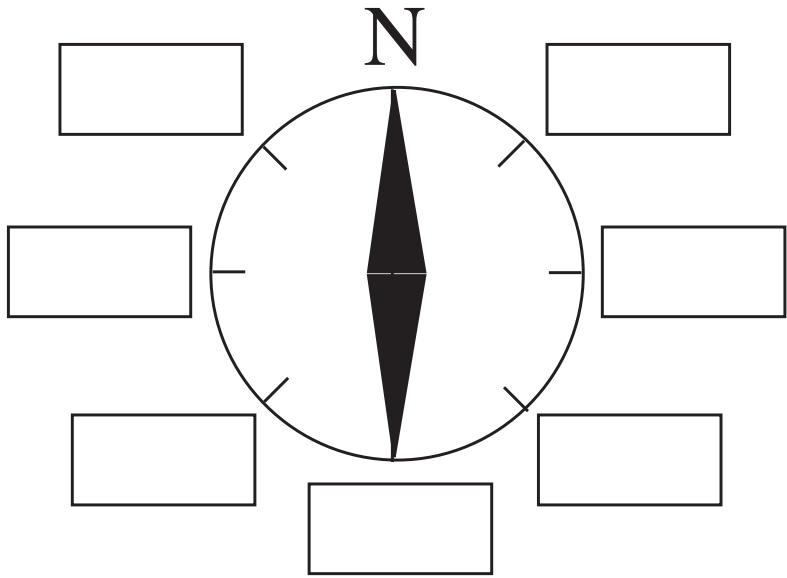

Start
point

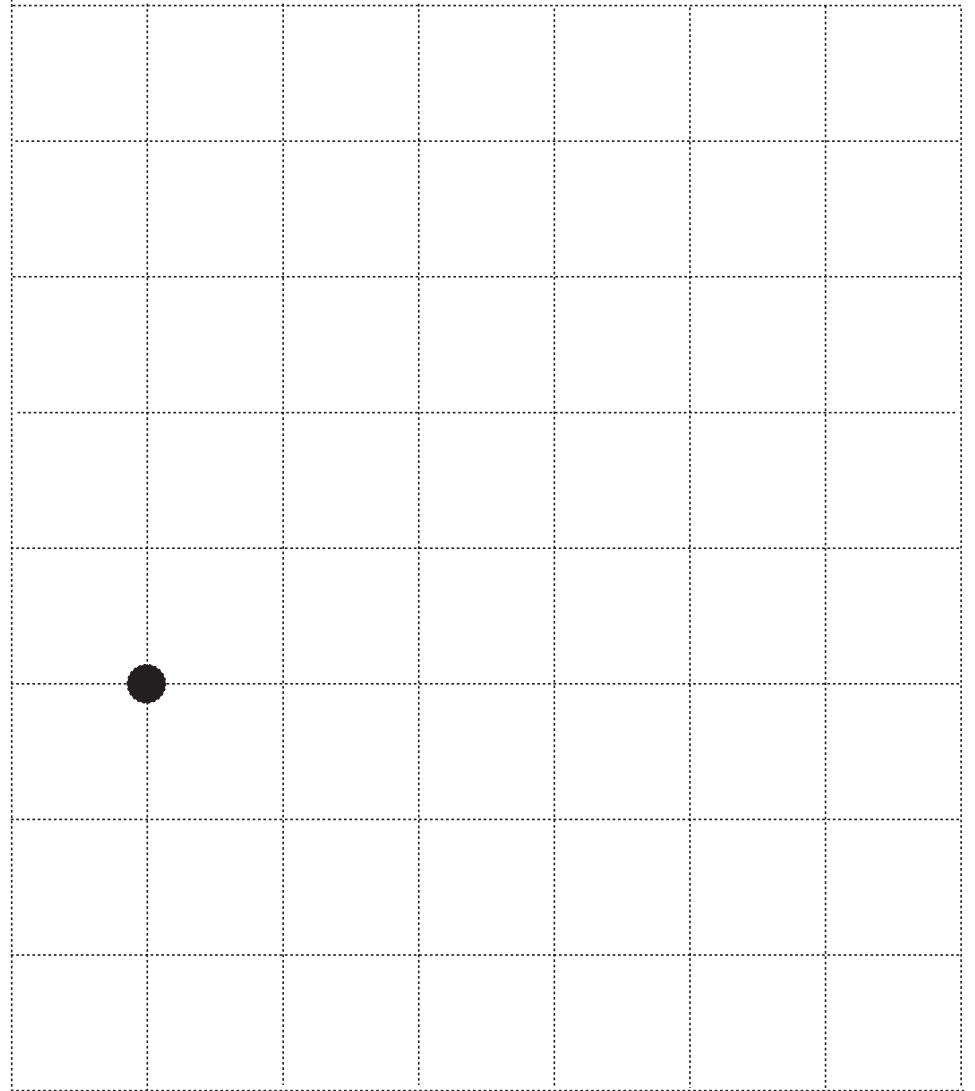

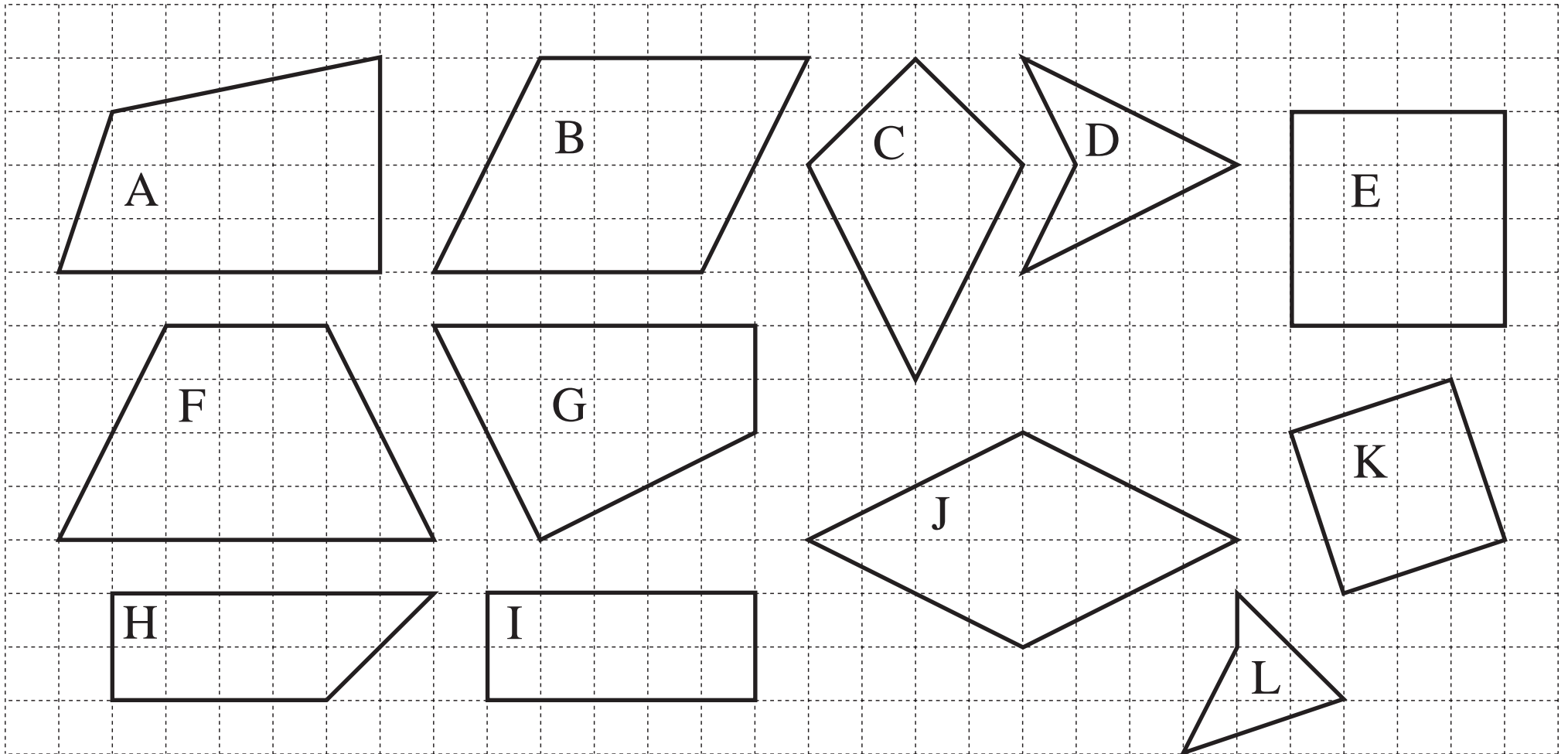

P: Opposite sides are parallel.

R: It has at least 1 right angle.

S: It has line symmetry.

C: It is convex.

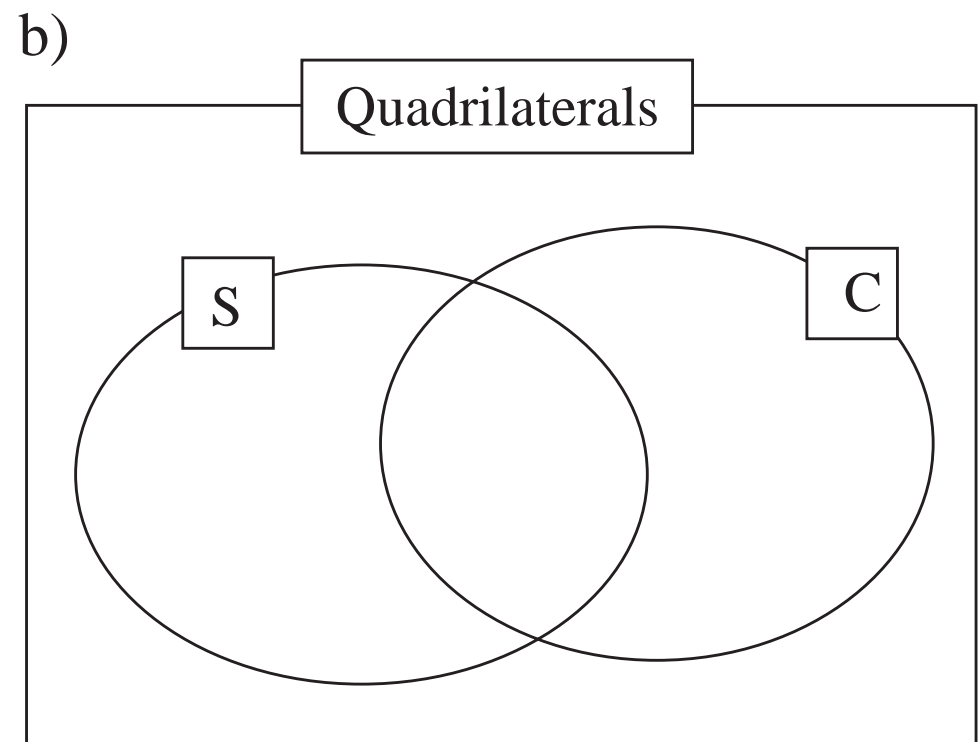
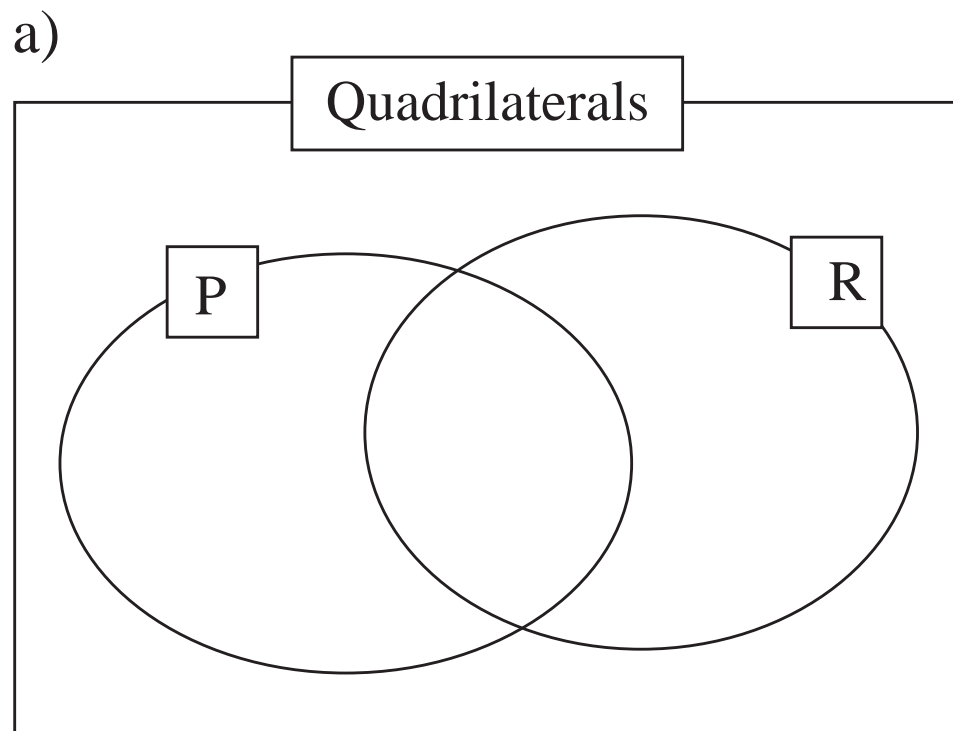

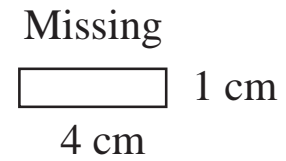
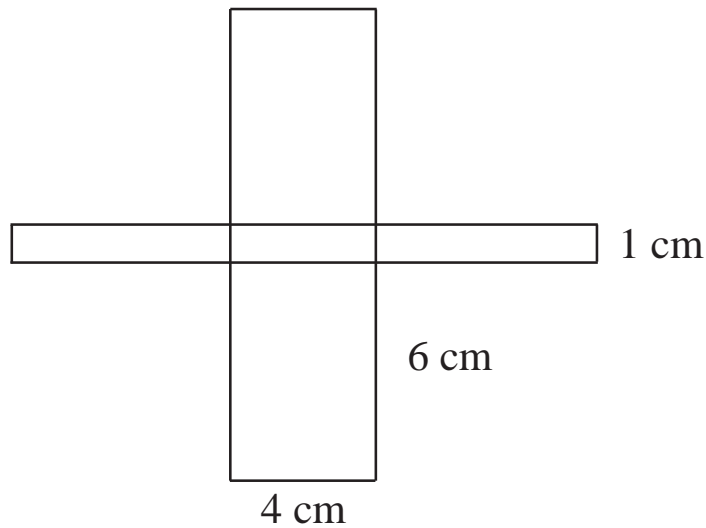
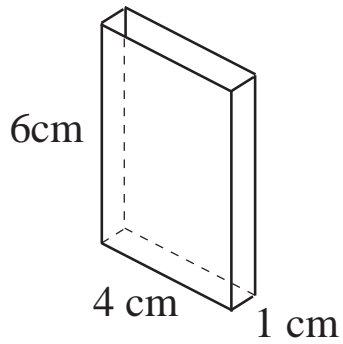
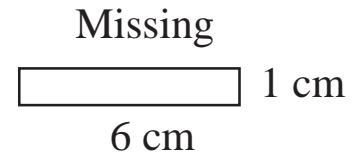
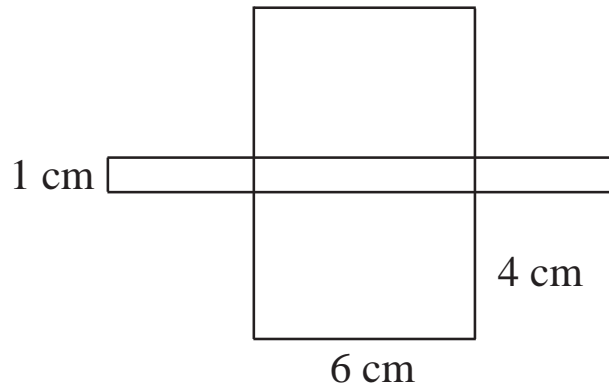
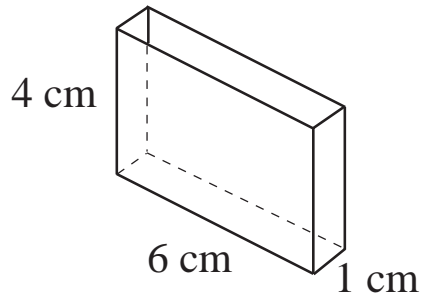
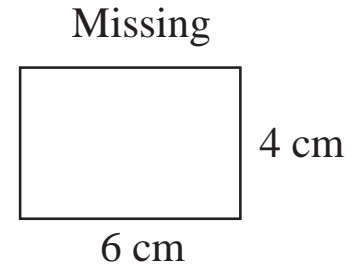
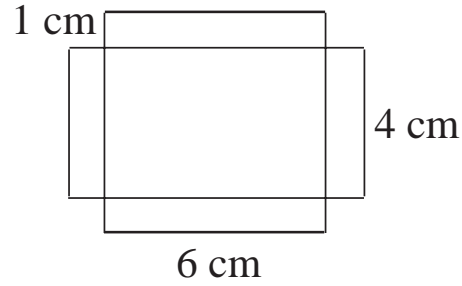
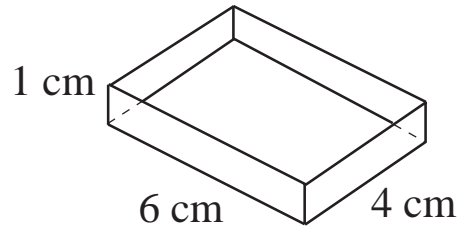

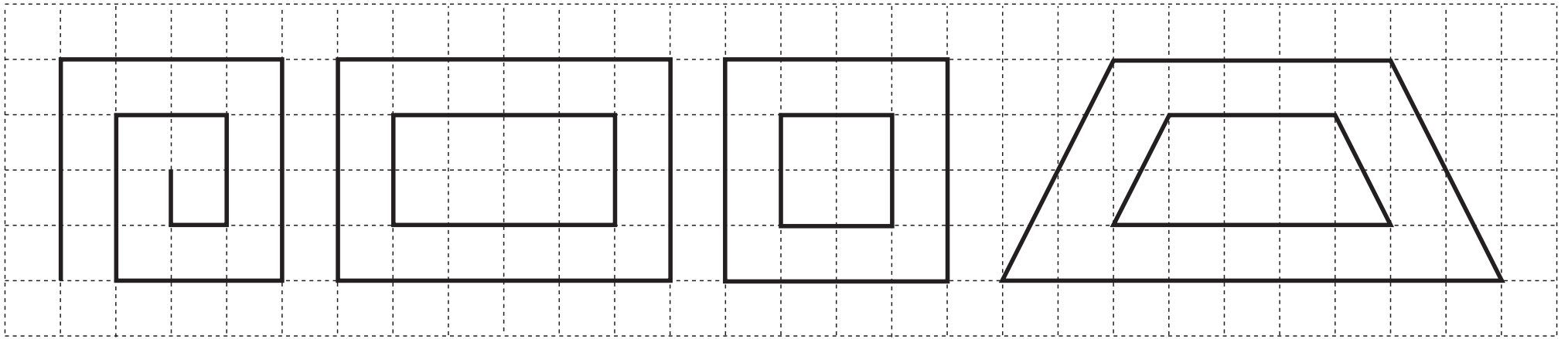

LP 54/5

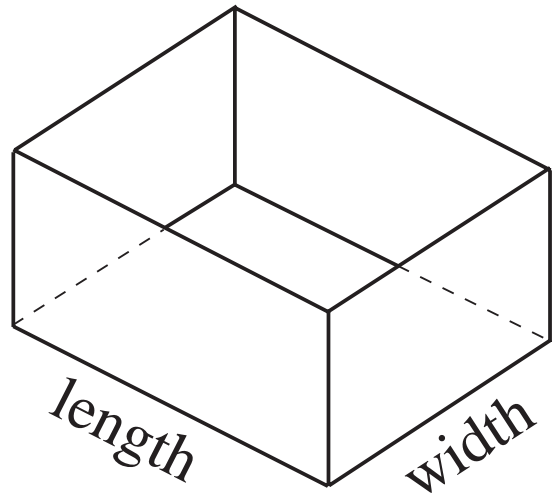

height

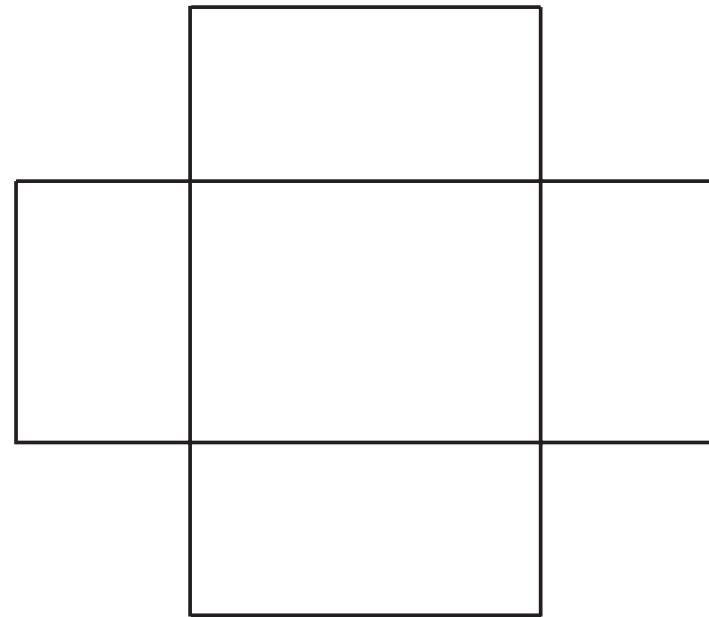

LP 55/1

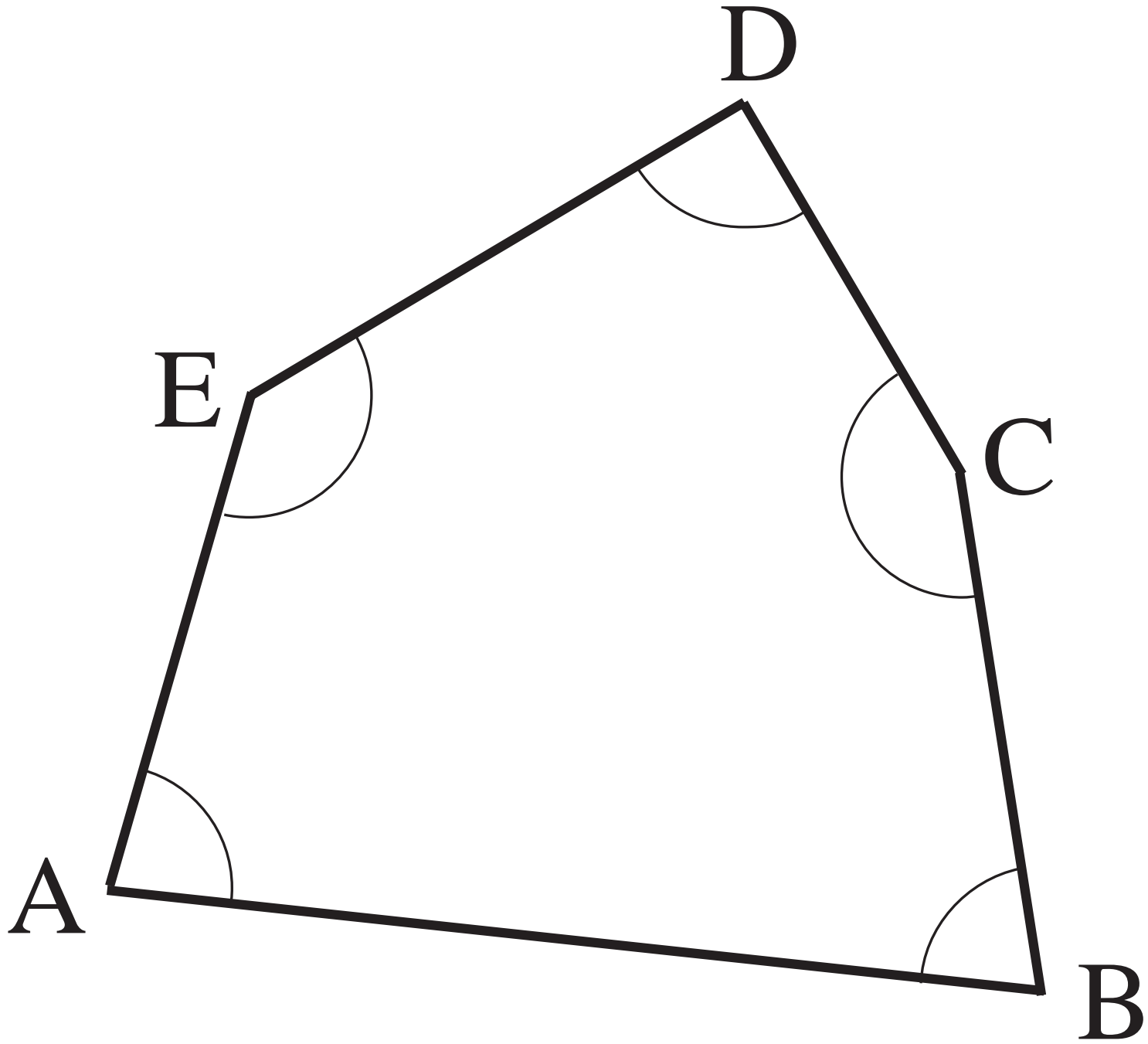

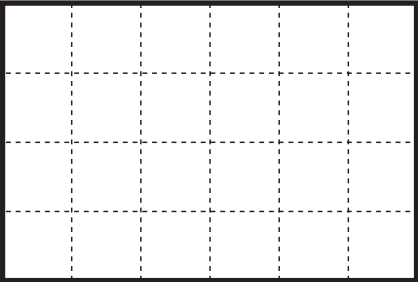
a) 

$A =$
 $P =$

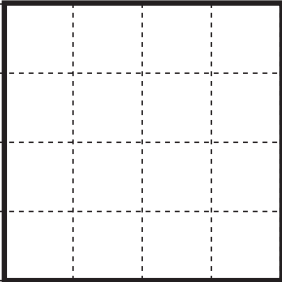
b) 

$A =$
 $P =$

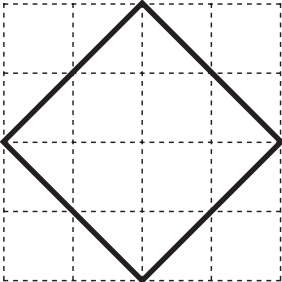
d) 

$A =$
 $P =$

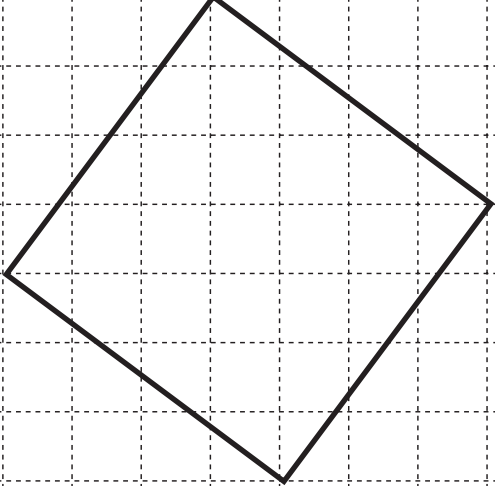
e) 

$A =$
 $P =$

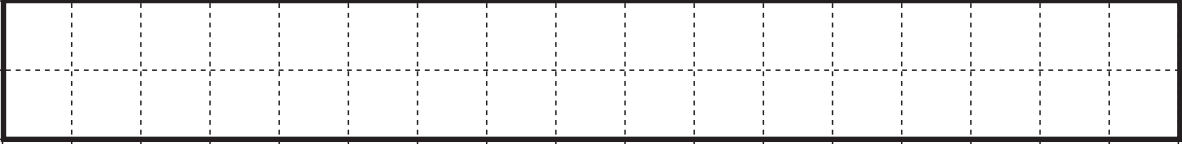
c) 

$A =$
 $P =$

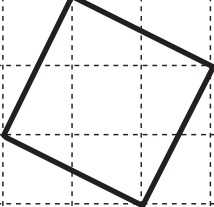
f) 

$A =$
 $P =$

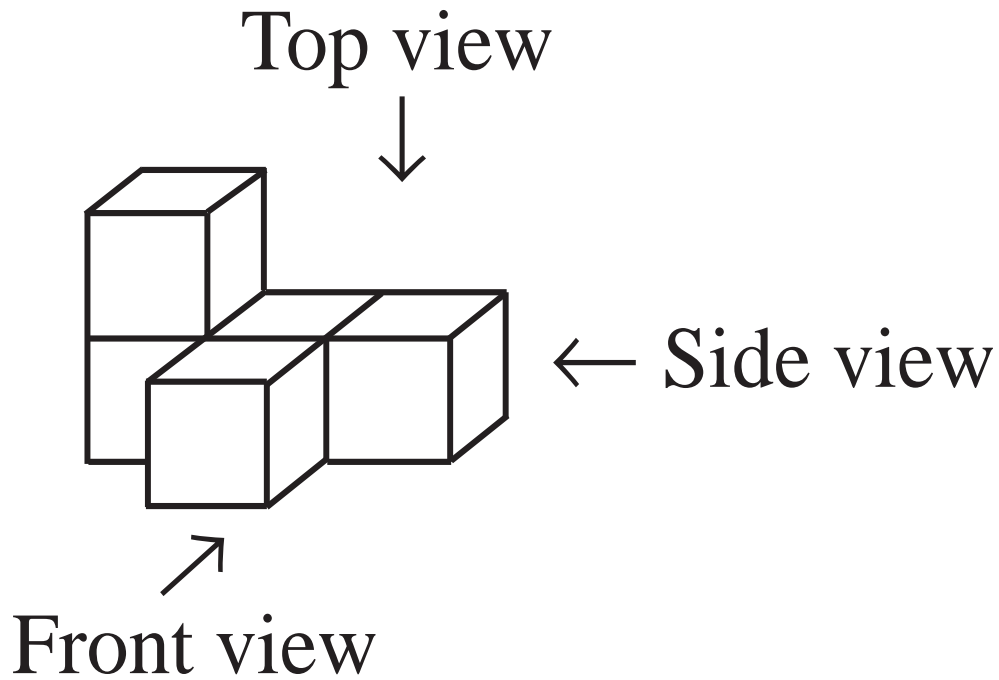

Front view Side view



Top view Ground plan

<i>a</i>	1234	432	7200	3100		4052	4231	
<i>b</i>	4321	8600	2800		3333	1796		3030
<i>c</i>	5555	9032		8000	5950		8462	6707

LP 56/1

<i>x</i>	3142	40	0	300	140		3615	60		5420
<i>y</i>	3	70	5148	8		7	2		3	
<i>z</i>	9426	2800			2800	3500		5400	4800	5420



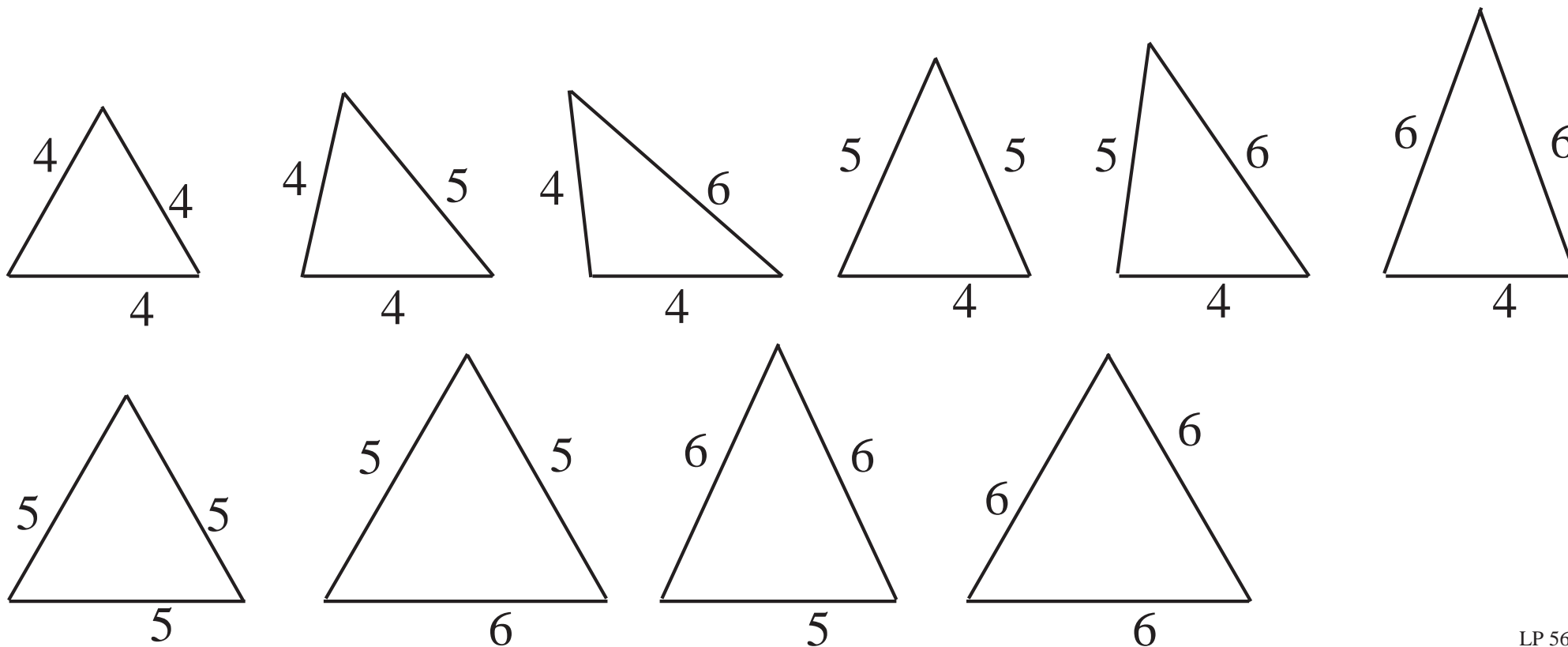

LP 56/2

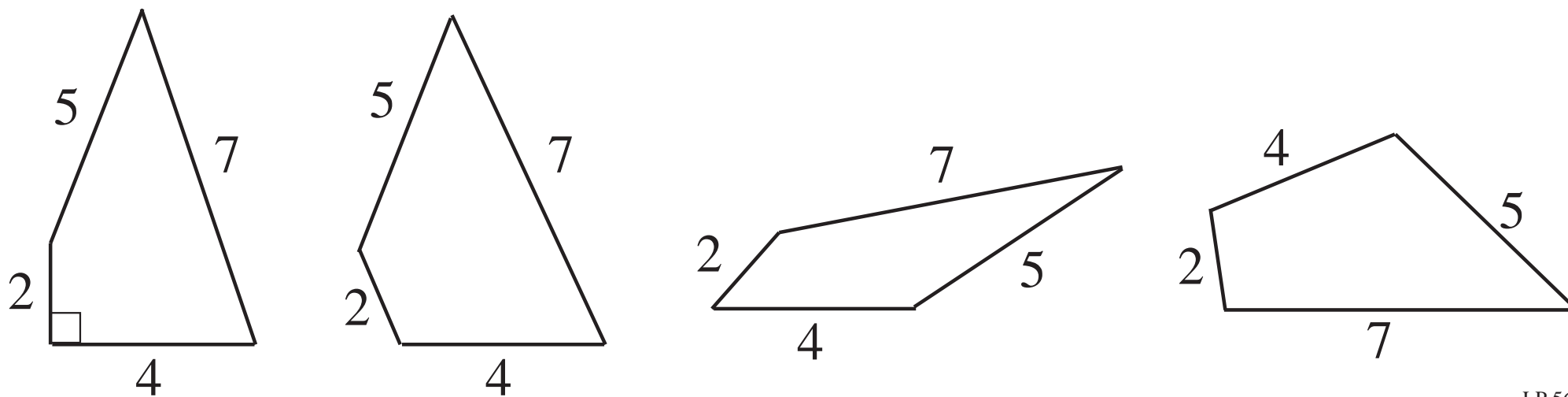

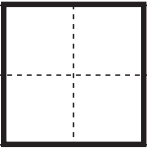

LP 56/3

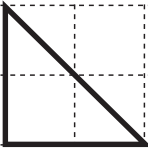

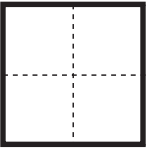
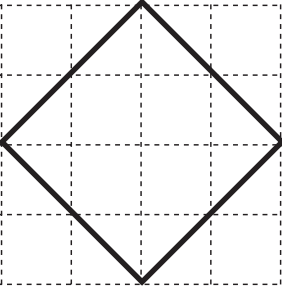
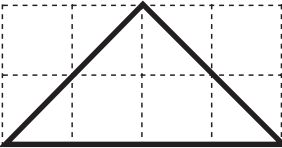
LP 56/4

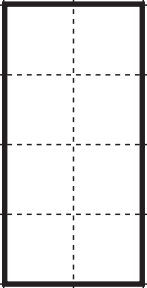
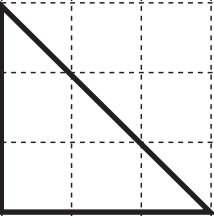
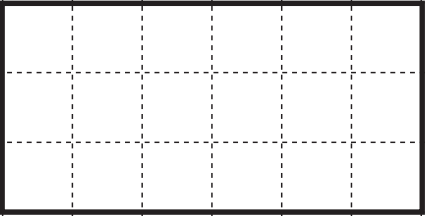
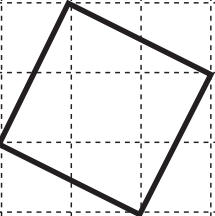
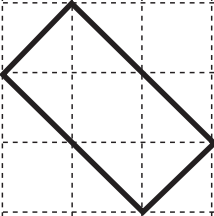
A  B  C  D  E  F  G 

H  I  J  K  L 

Units:  

a)

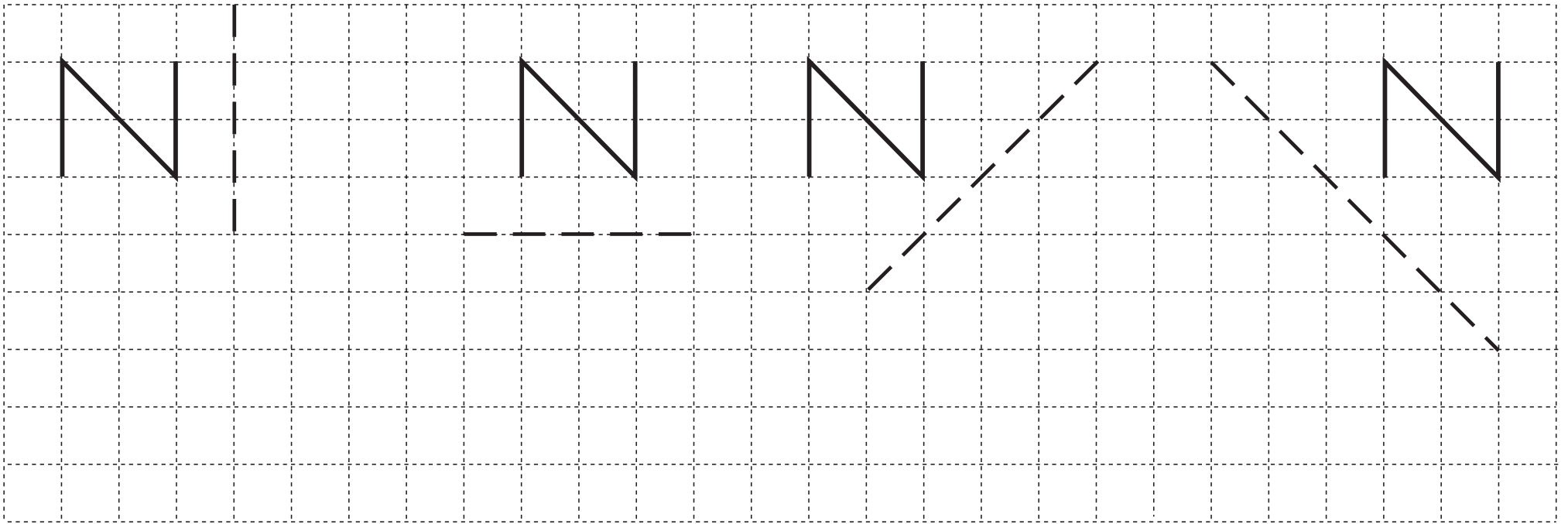

b)

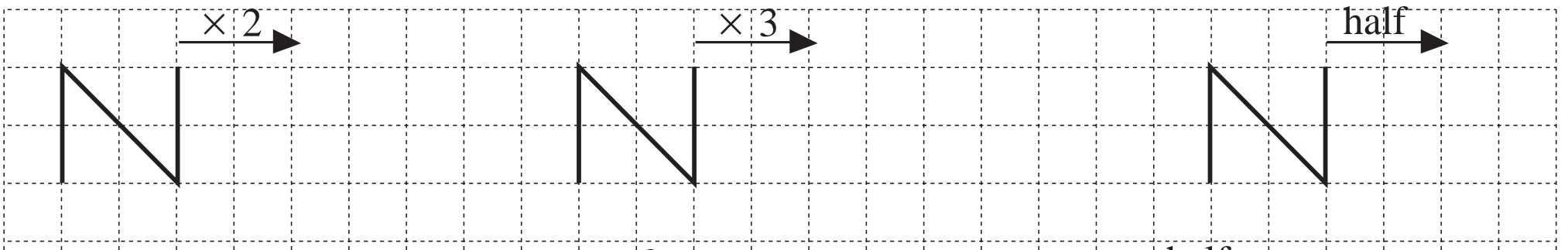

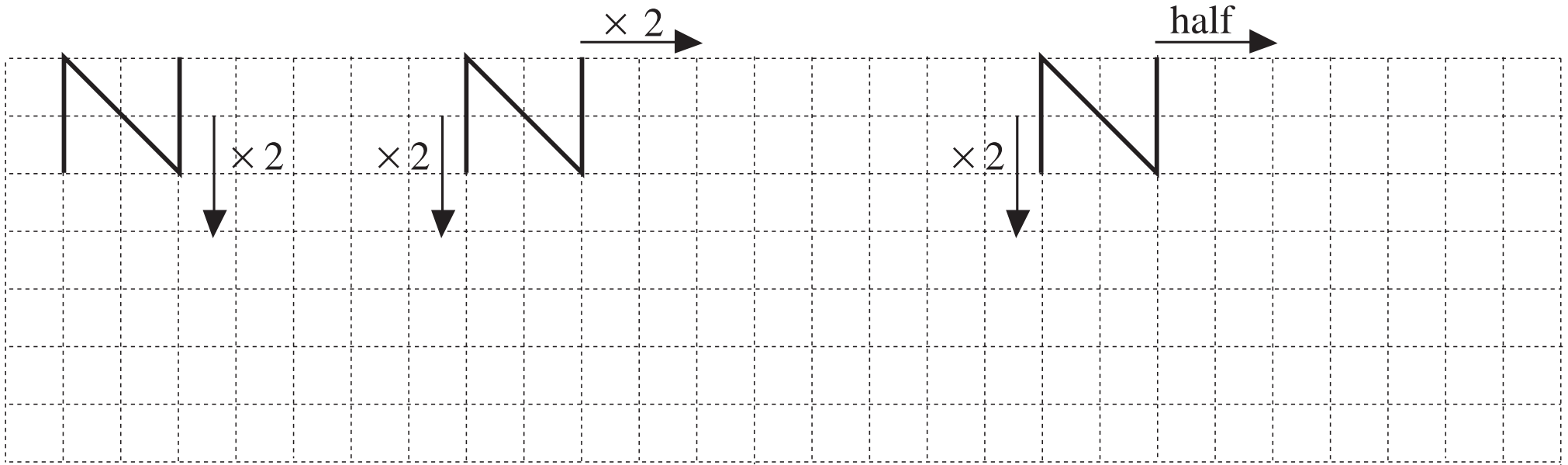

LP 56/7 Ext.

<i>a</i>	1 m 27 cm	420 mm	5 km	15 m 40 cm		1700 km		50 cm
<i>b</i>	5 m 8 cm	1680 mm	20 km		2800 mm		1 metre	

LP 57/1

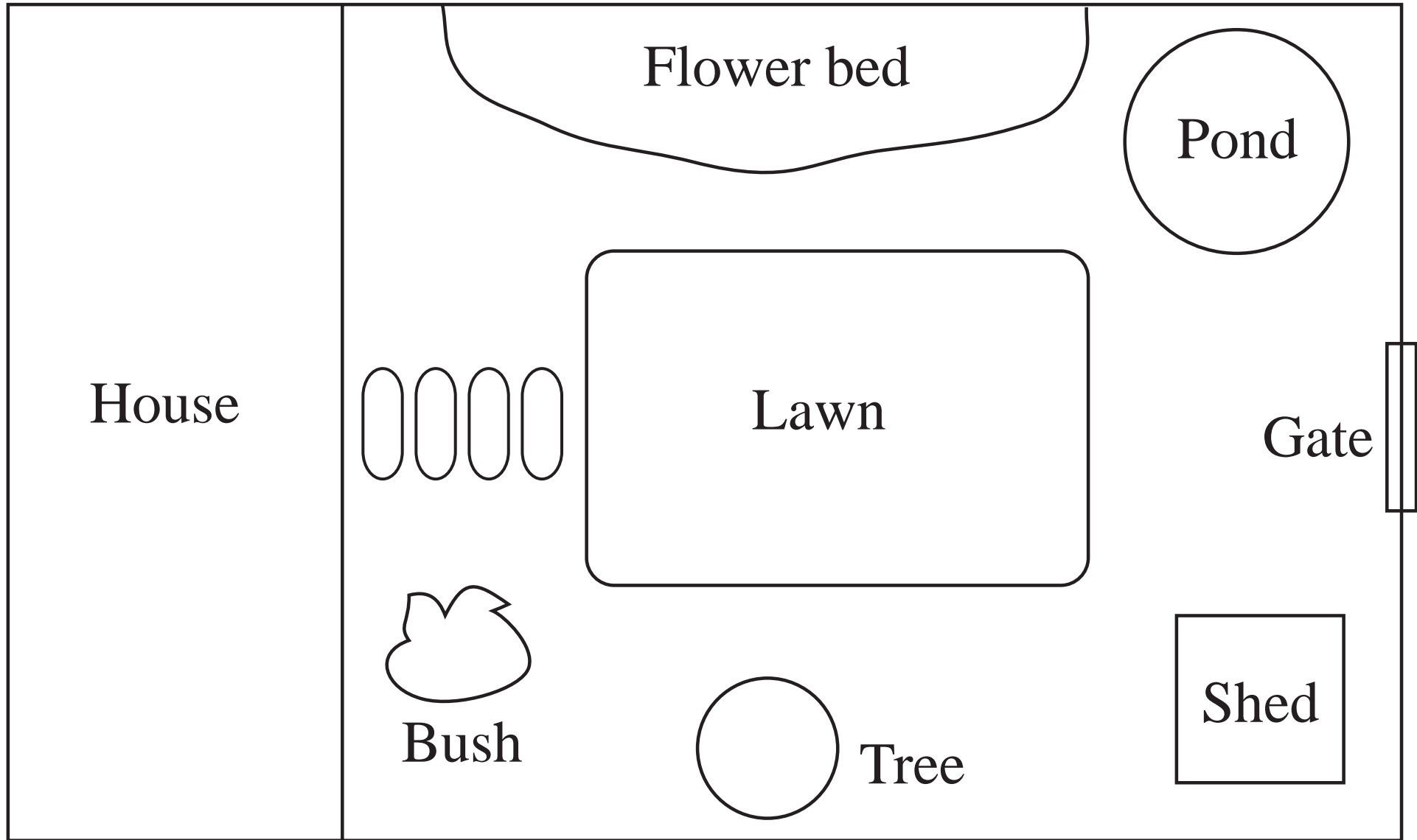

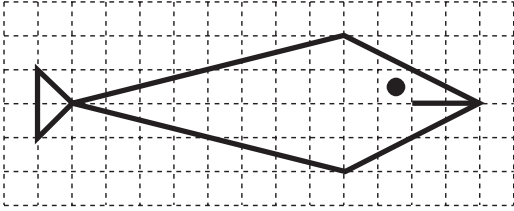

a)

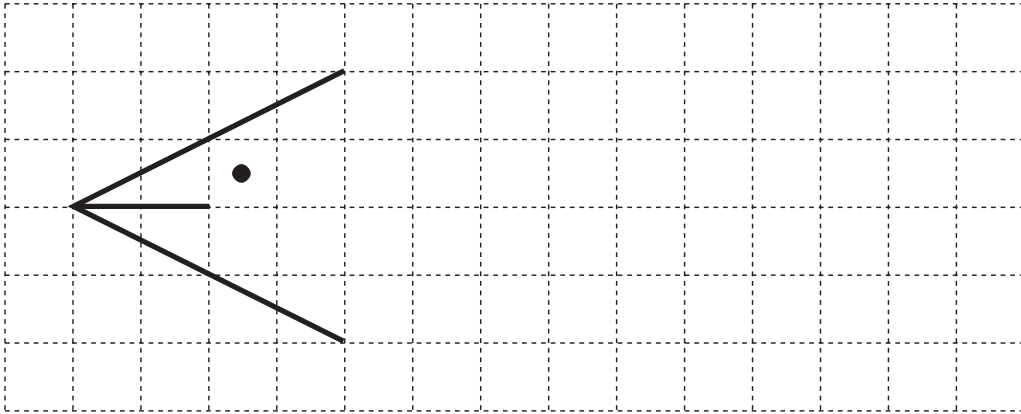

b)

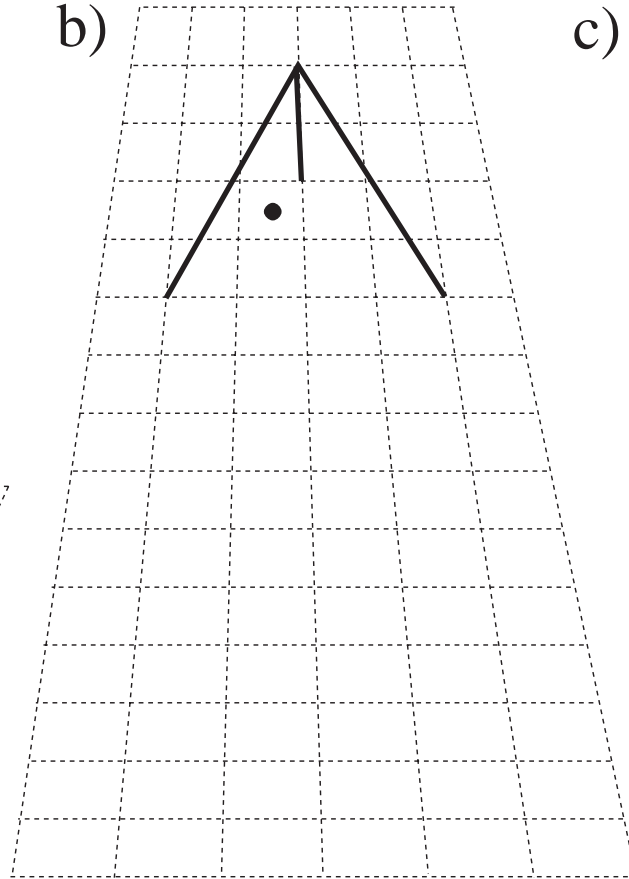

c)

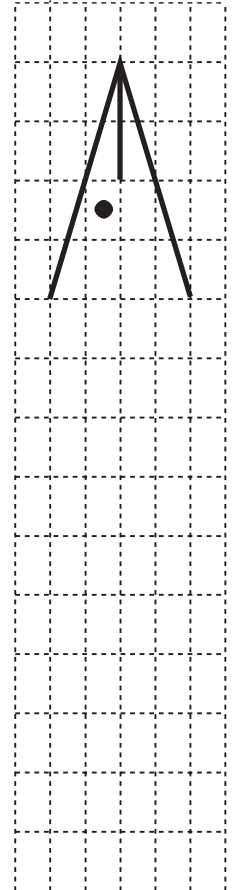

d)

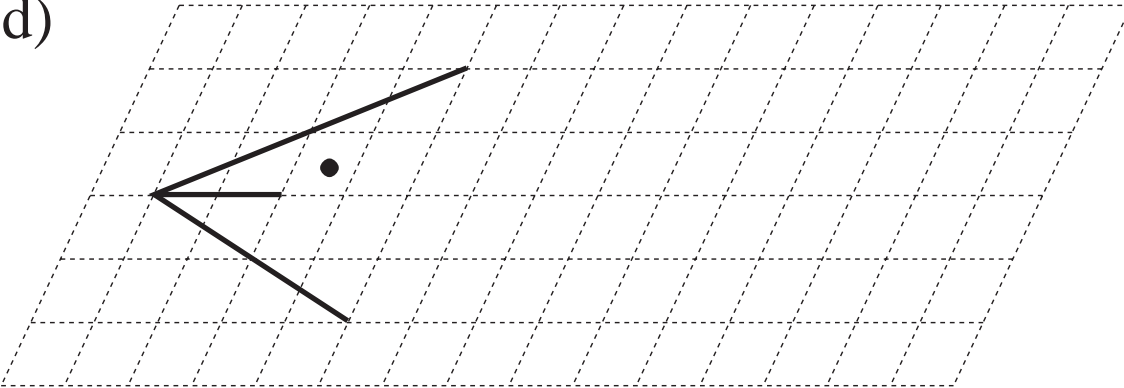

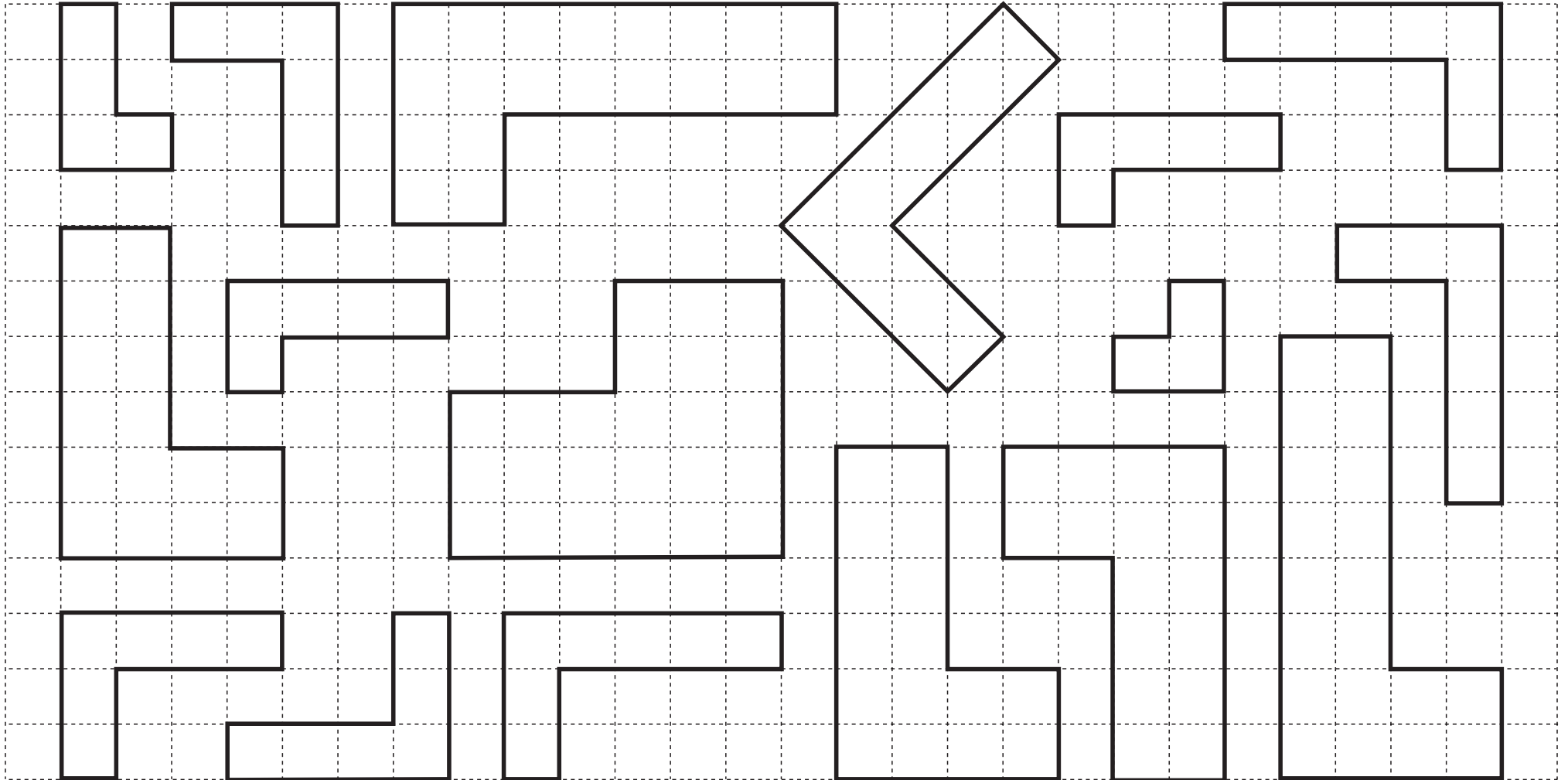

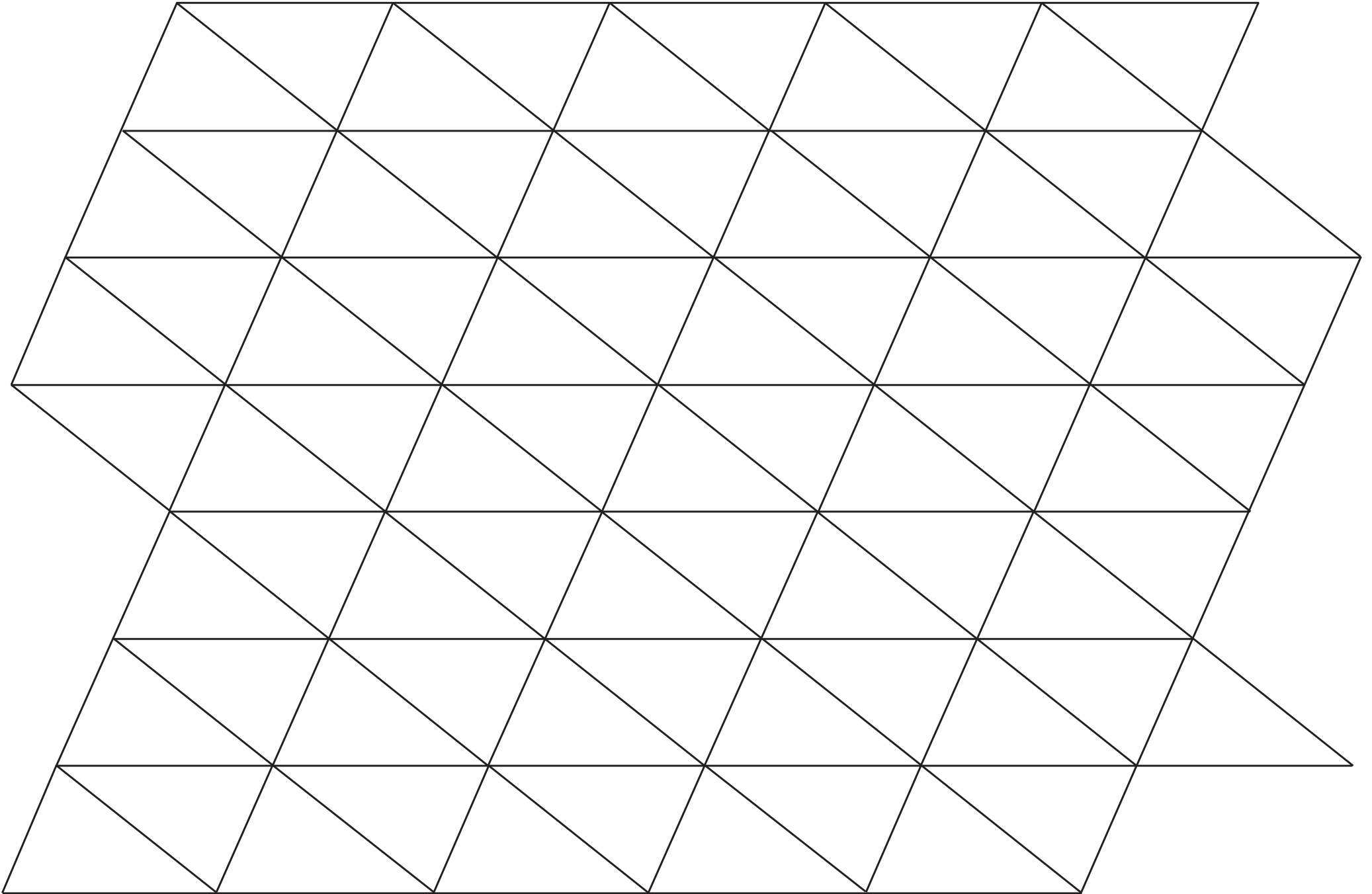



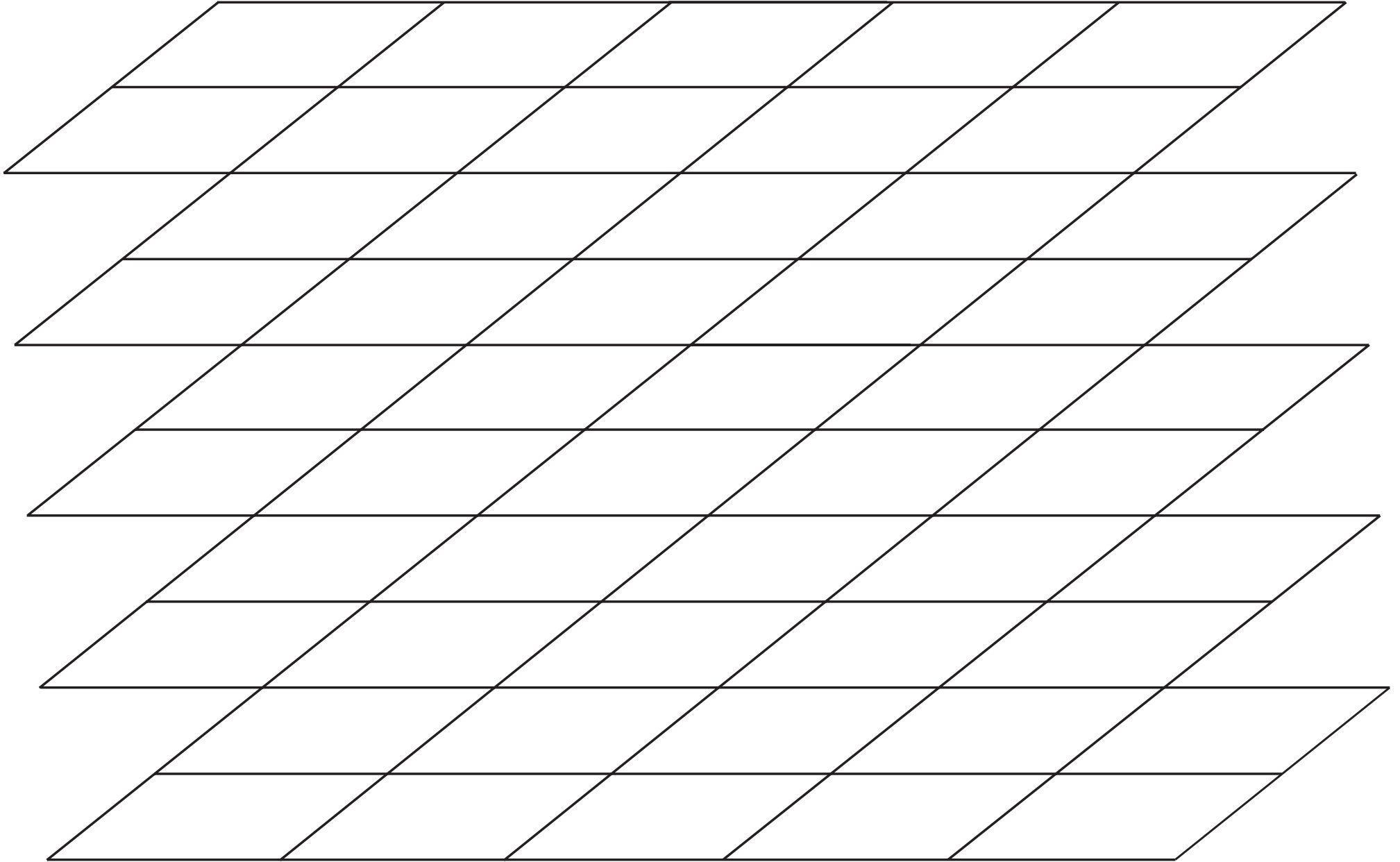

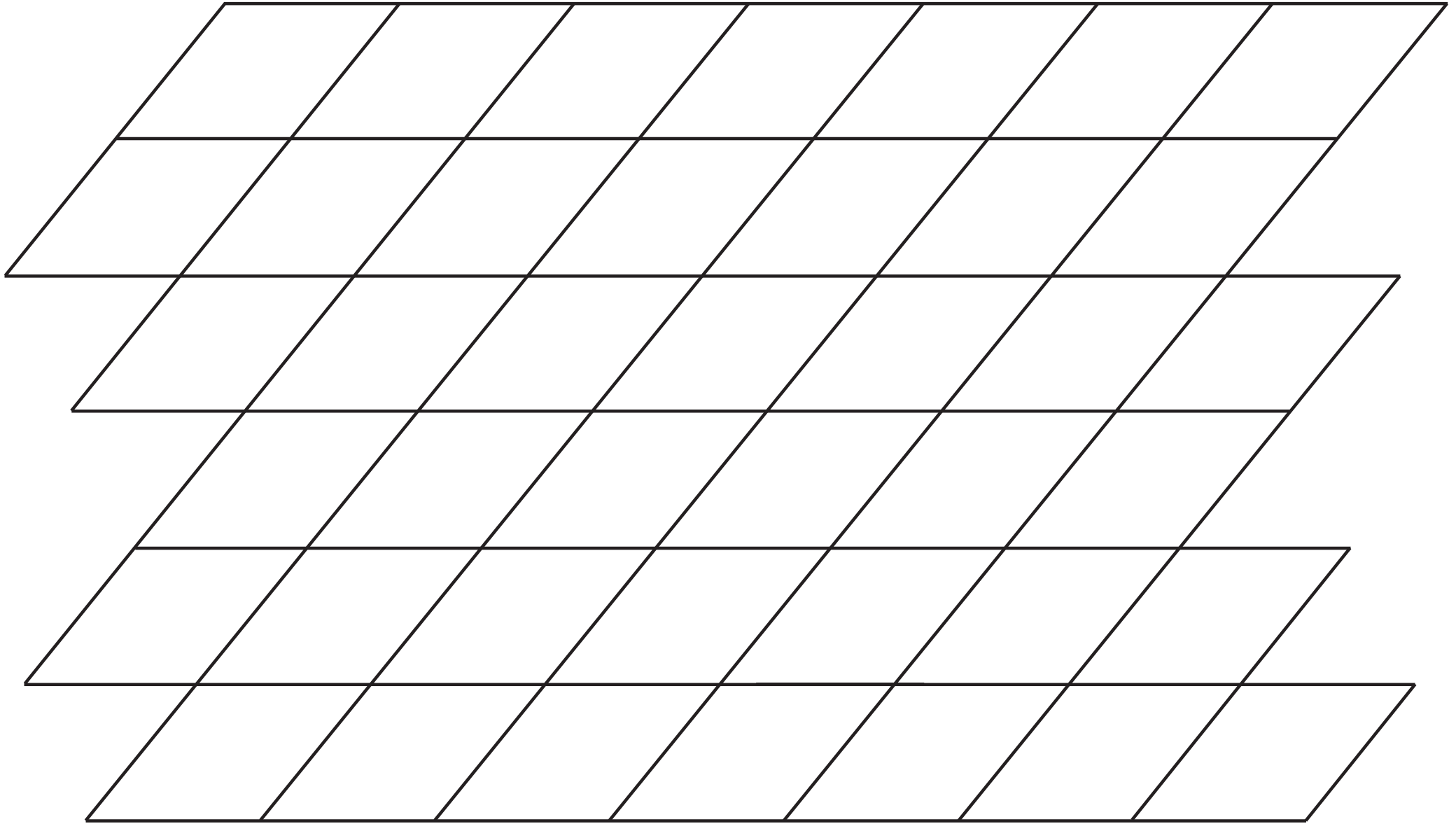

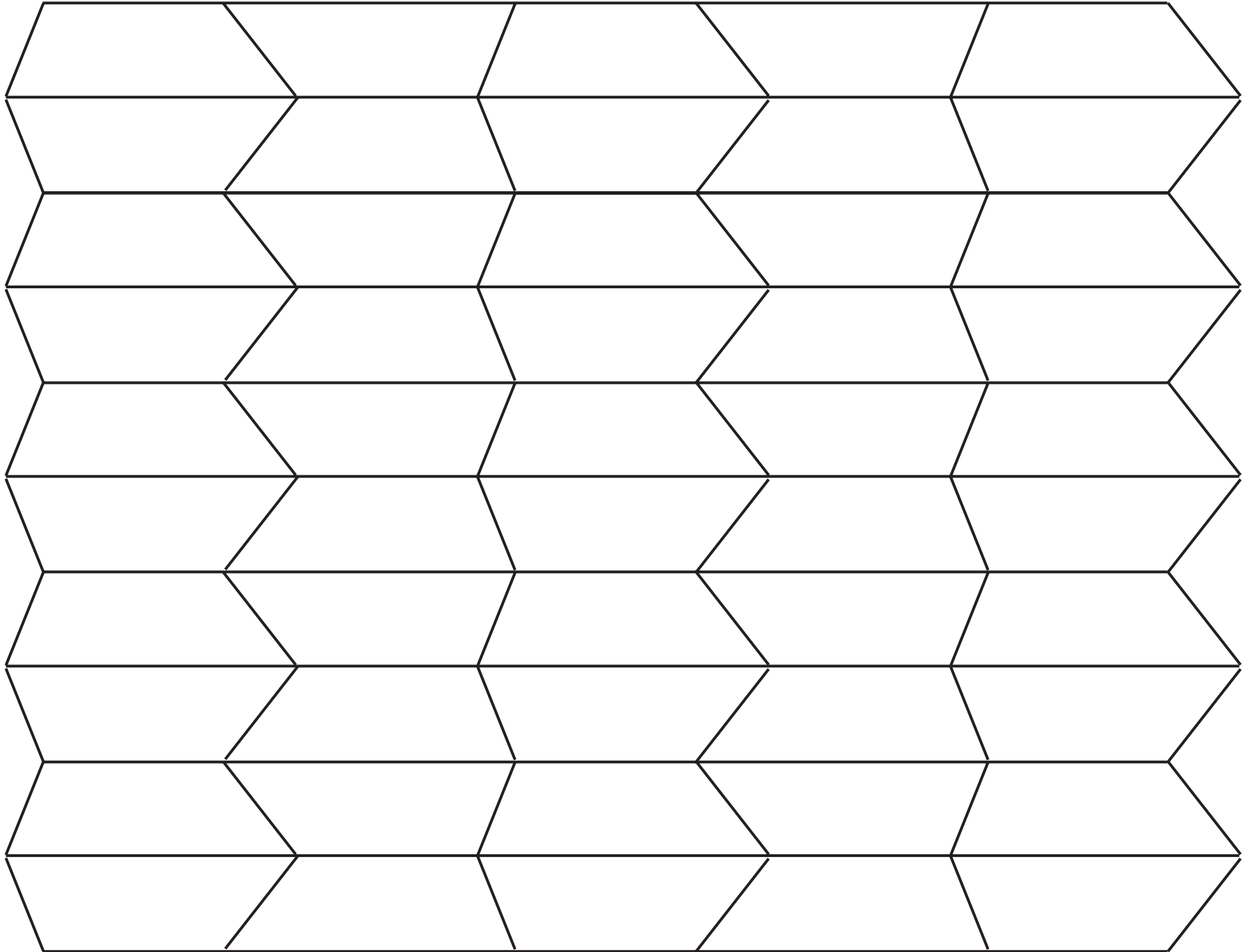

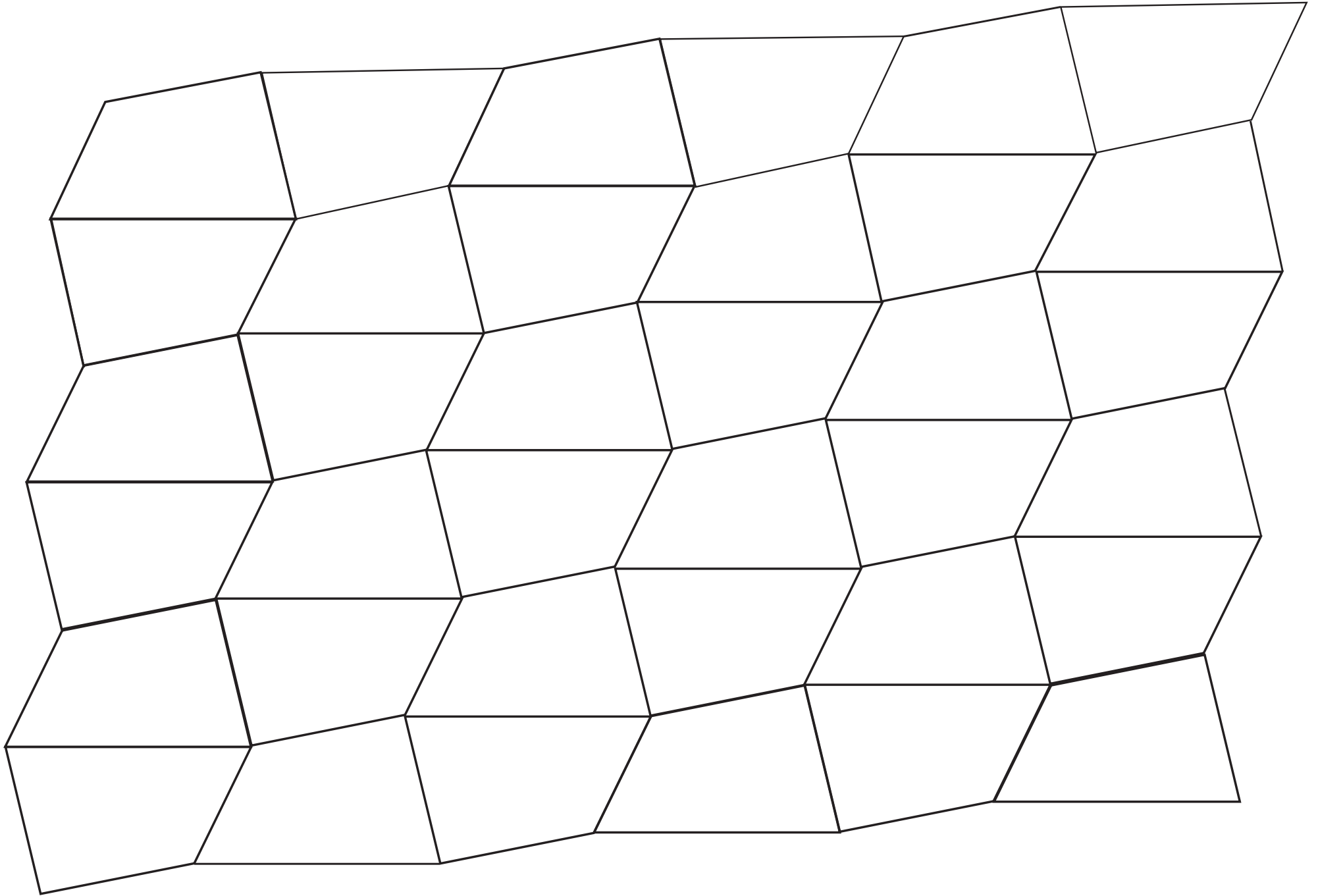

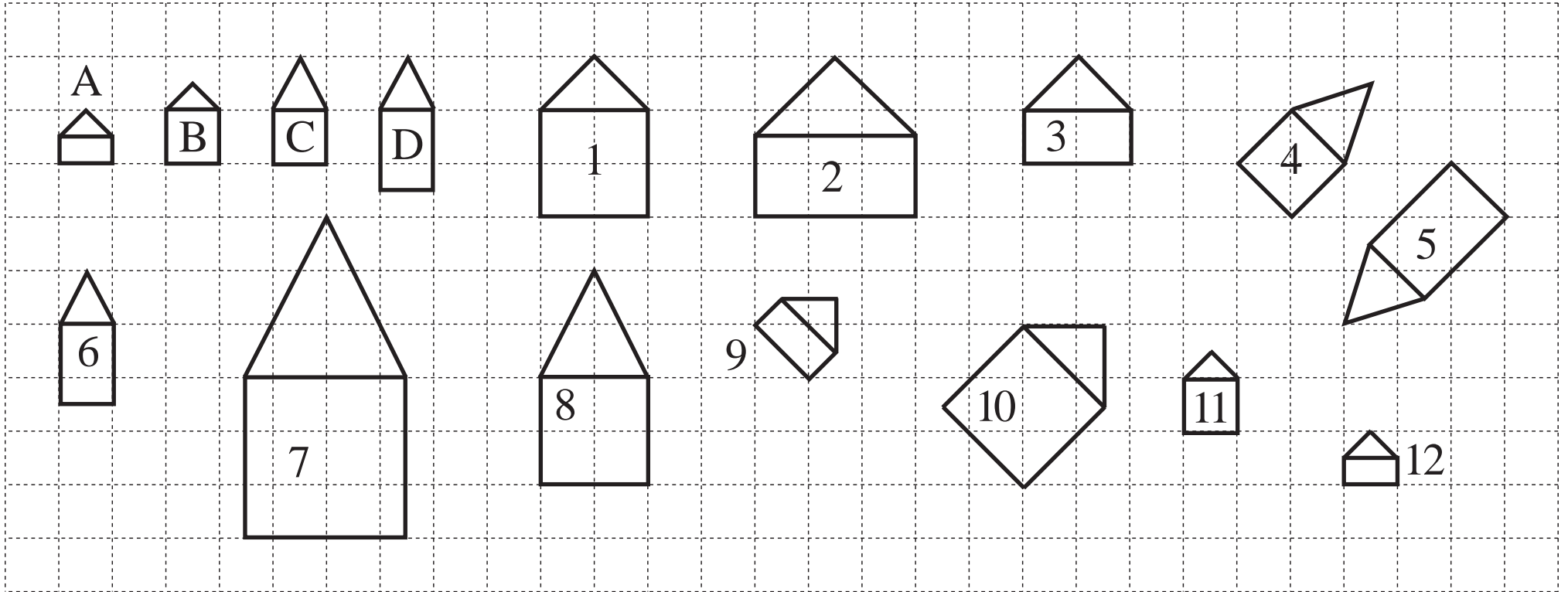

units:

①

$P =$ $A =$

②

$P =$ $A =$

③

$P =$ $A =$

④

$P =$ $A =$

⑤

$A =$ $P =$

LP 58/5

i)

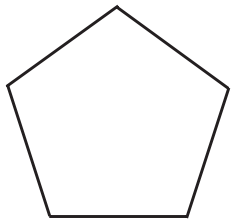

ii)

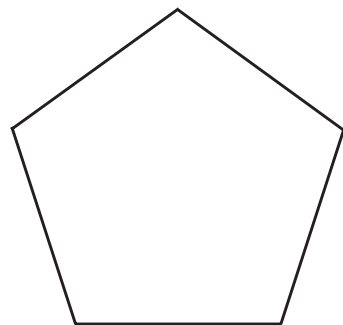

iii)

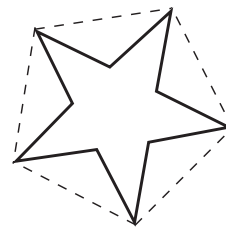

iv)

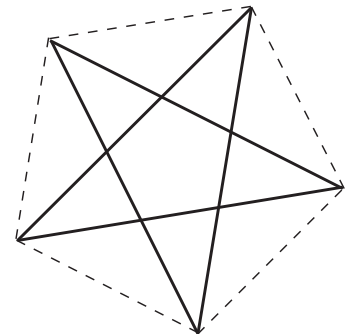

LP 58/6

a) $7 \text{ km } 300 \text{ m} = \boxed{} \text{ m}$

b) $5630 \text{ m} = \boxed{} \text{ km } \boxed{} \text{ m}$

$4 \text{ km } 83 \text{ m} = \boxed{} \text{ m}$

$3043 \text{ m} = \boxed{} \text{ km } \boxed{} \text{ m}$

$3 \text{ km } 120 \text{ m} = \boxed{} \text{ m}$

$9302 \text{ m} = \boxed{} \text{ km } \boxed{} \text{ m}$

$16 \text{ km } 9 \text{ m} = \boxed{} \text{ m}$

$14 \text{ 150 m} = \boxed{} \text{ km } \boxed{} \text{ m}$

a) 640 cm \approx <input type="text"/> m	b) 398 cm \approx <input type="text"/> m	c) 5 m 5 cm \approx <input type="text"/> m
450 cm \approx <input type="text"/> m	287 cm \approx <input type="text"/> m	5 m 50 cm \approx <input type="text"/> m
530 cm \approx <input type="text"/> m	438 cm \approx <input type="text"/> m	6048 mm \approx <input type="text"/> m
680 cm \approx <input type="text"/> m	648 mm \approx <input type="text"/> m	5005 mm \approx <input type="text"/> m

a)

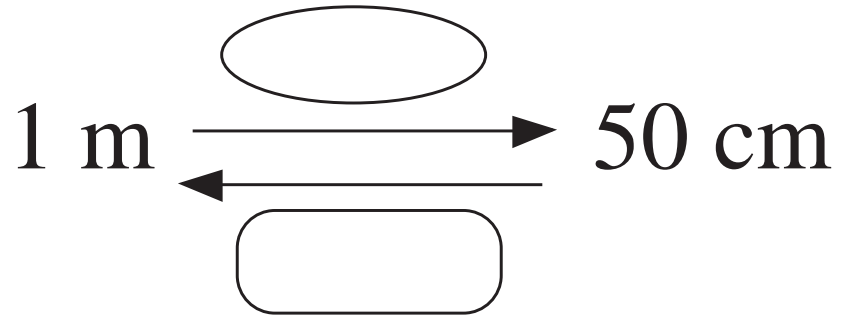

b)

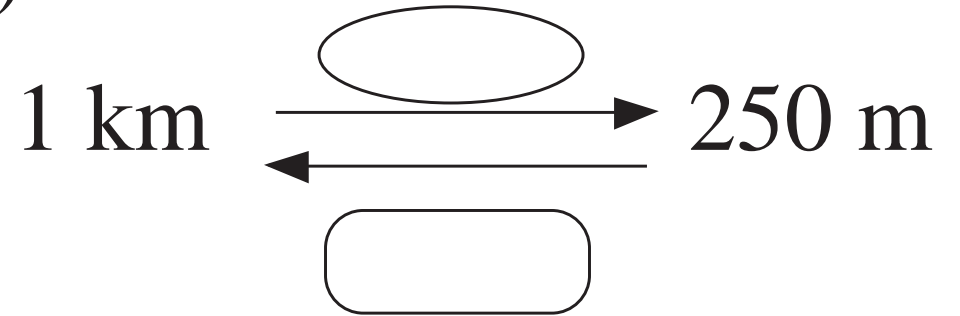

c)

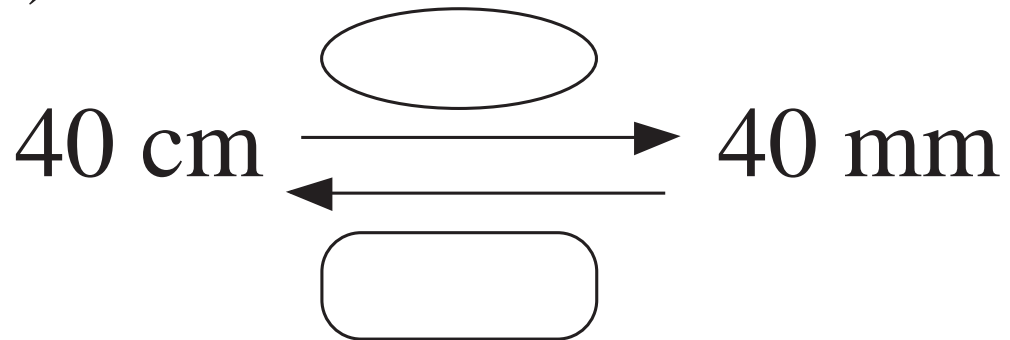

d)

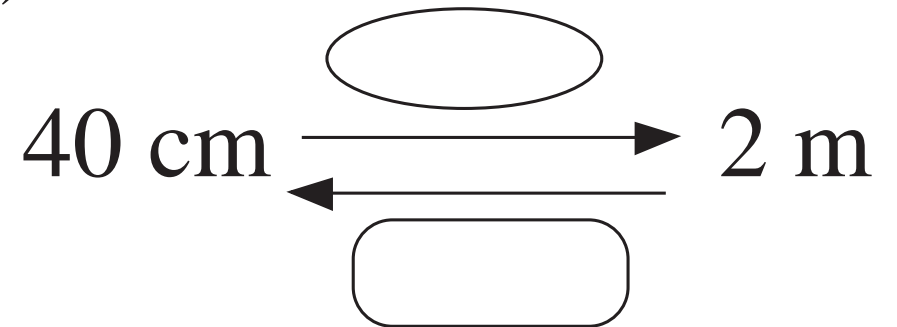

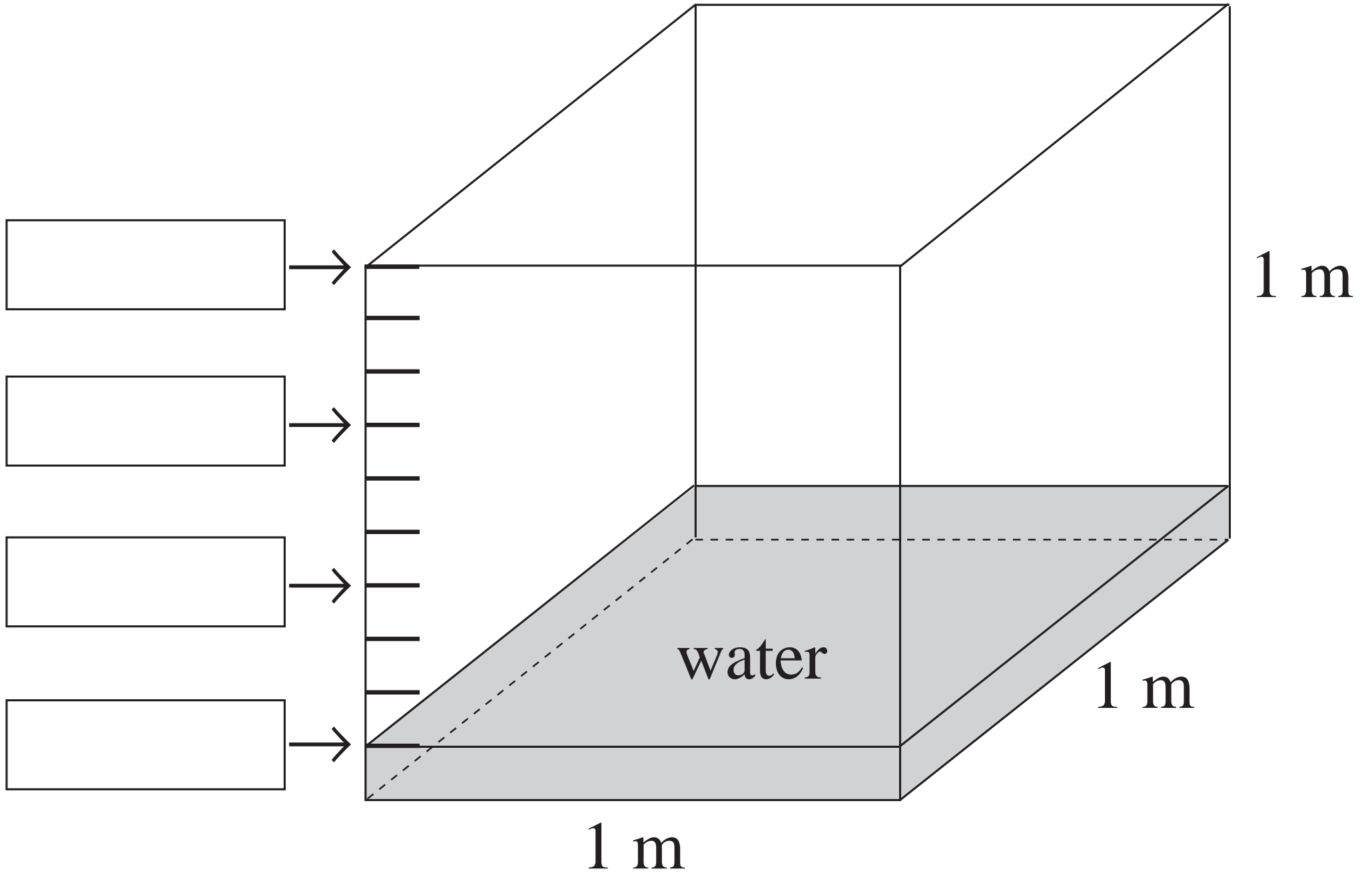

Level of water	10 cm	20 cm	40 cm			100 cm	1 cm		1 mm
Amount of water	100 litres			500 litres	700 litres			30 litres	7 litres

LP 59/4b

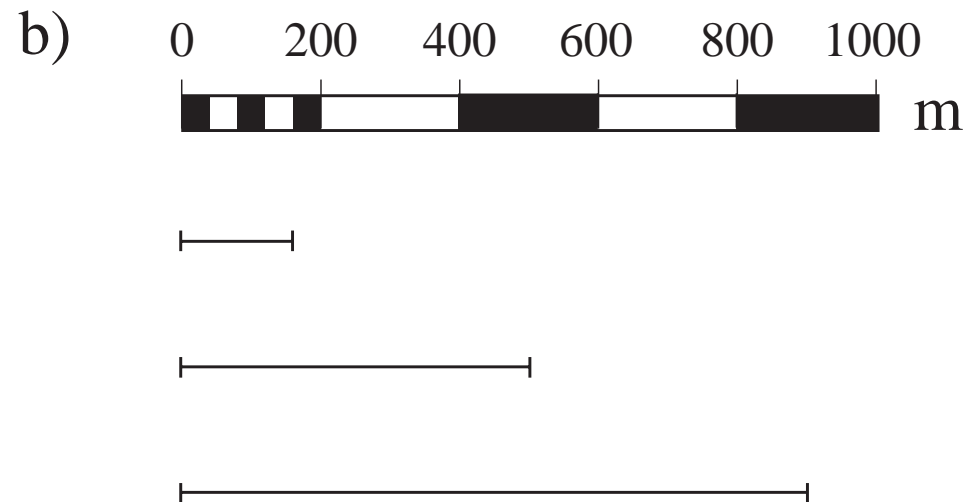
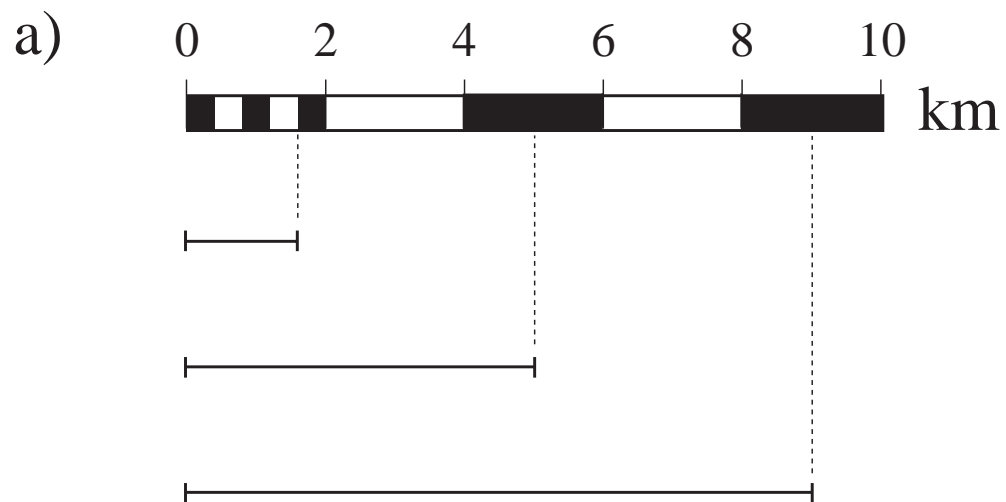

LP 59/6

a)

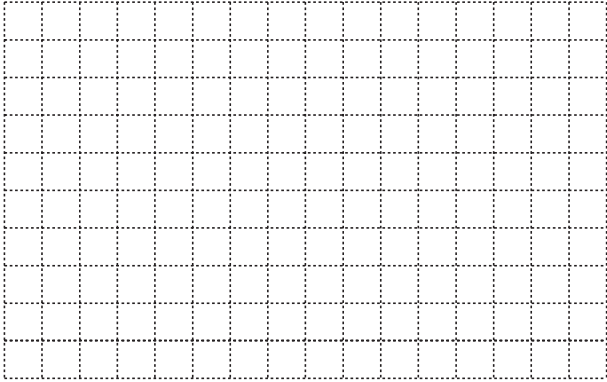

b)

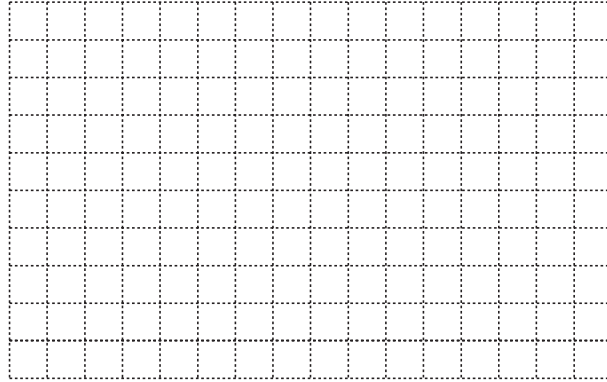

c)

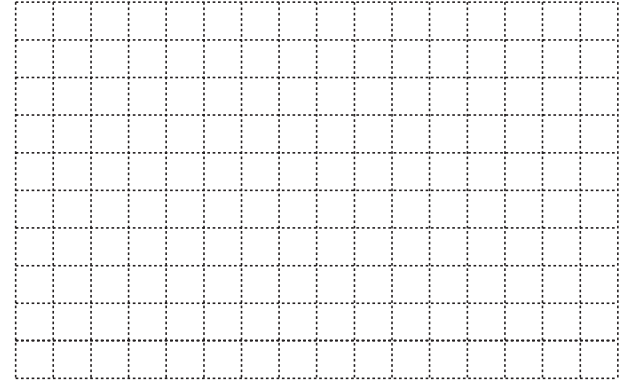

LP 59/7

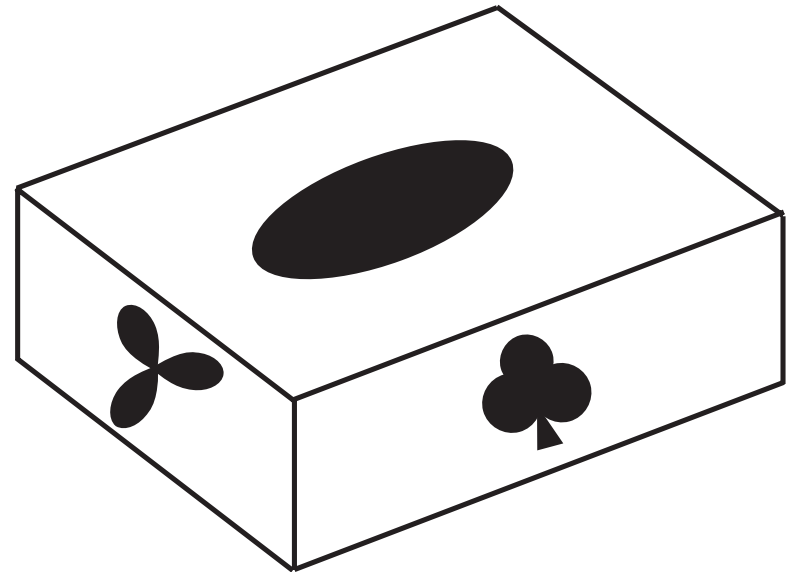
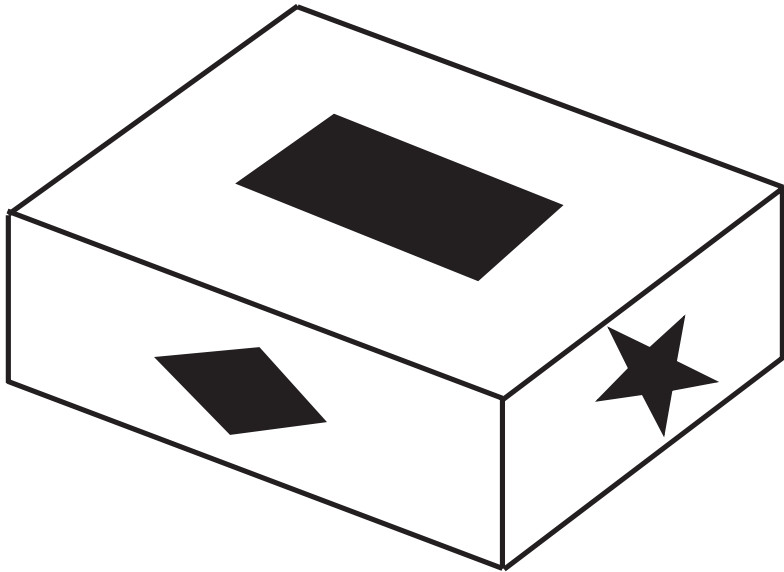

LP 59/9a

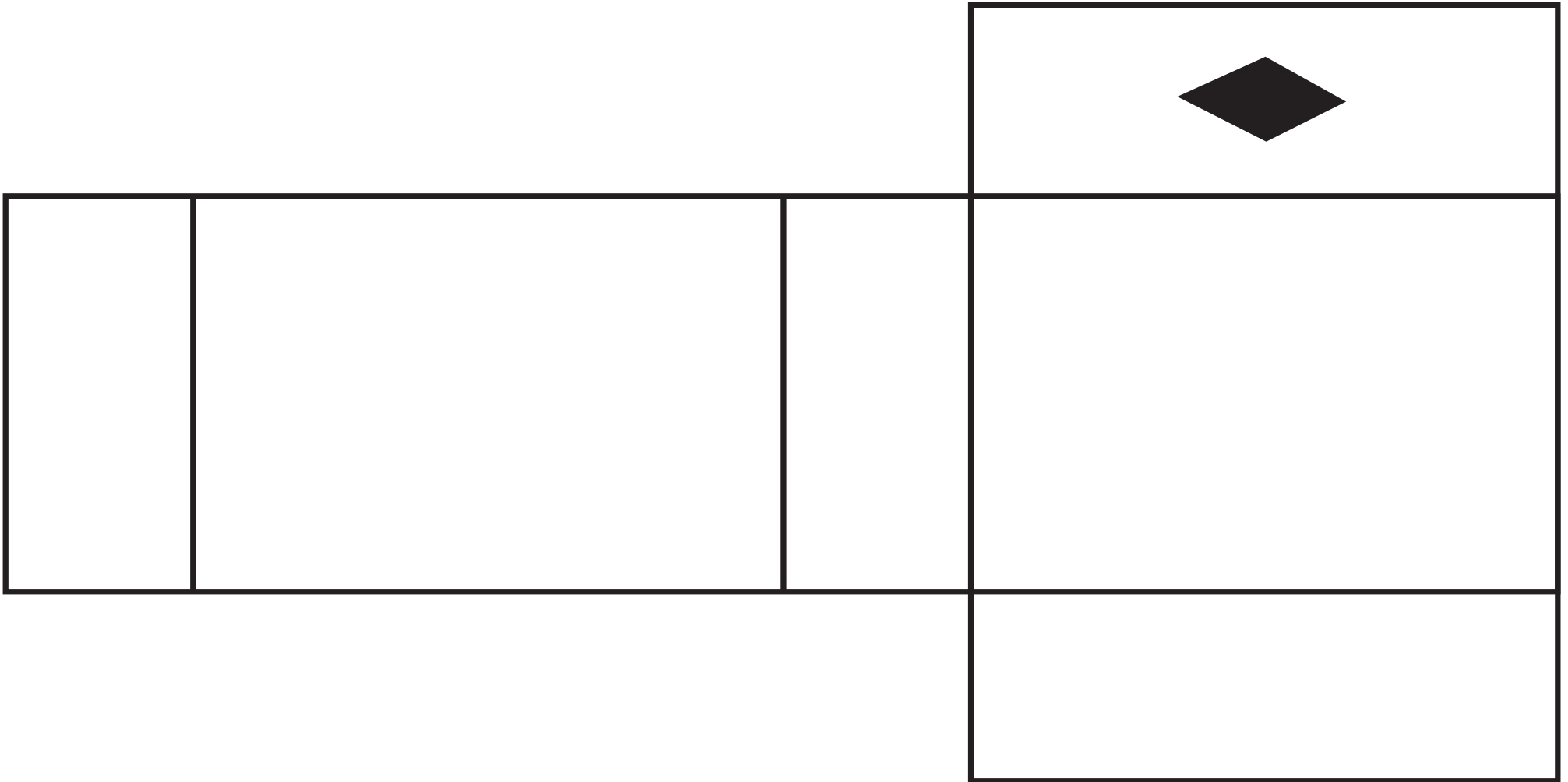

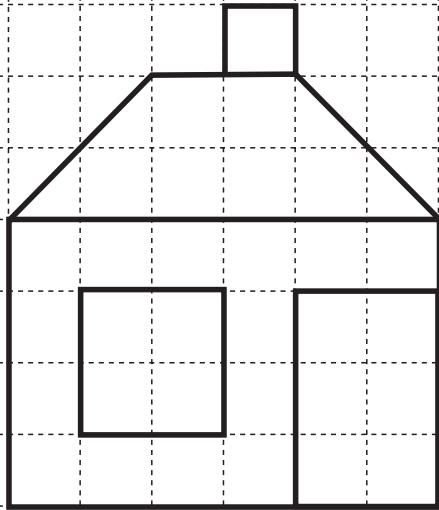

a)

b)

a)

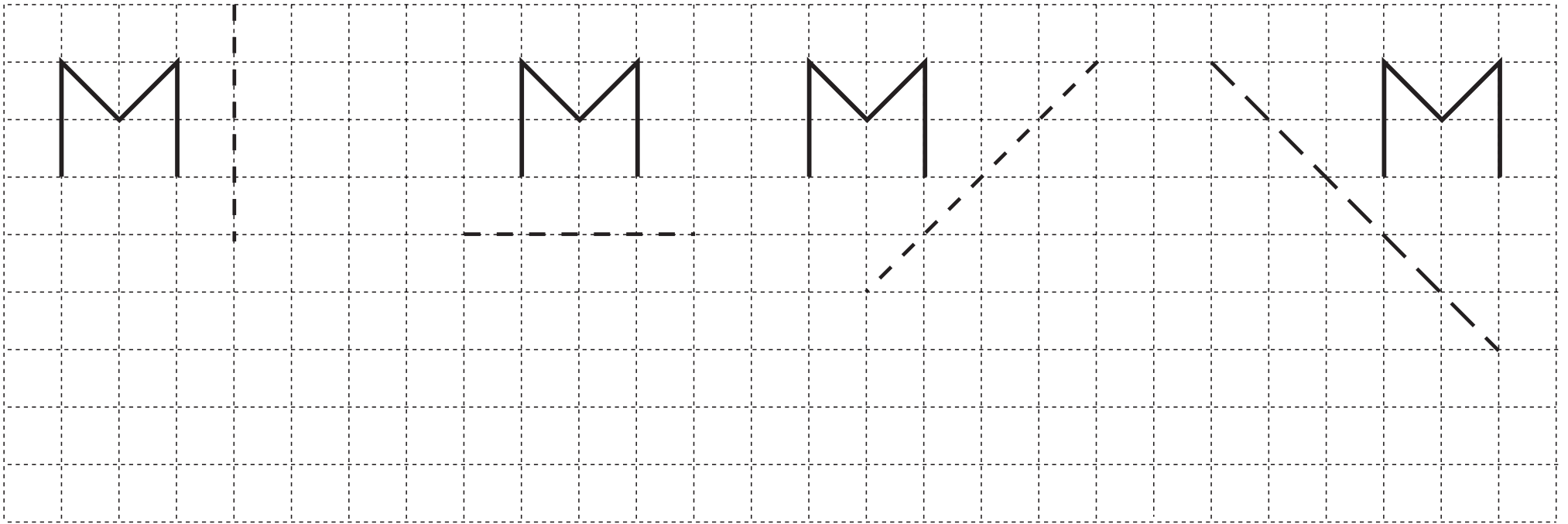

b)

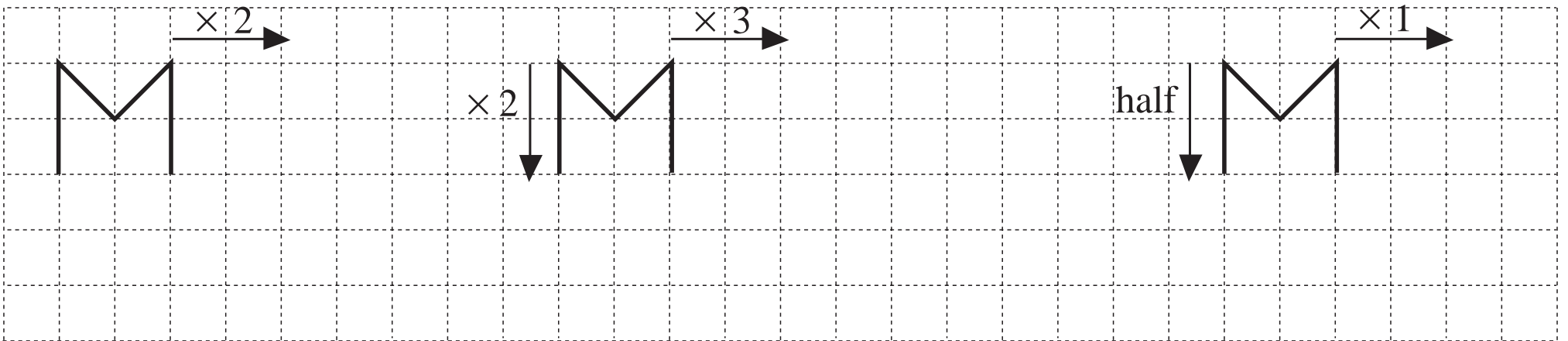

a)

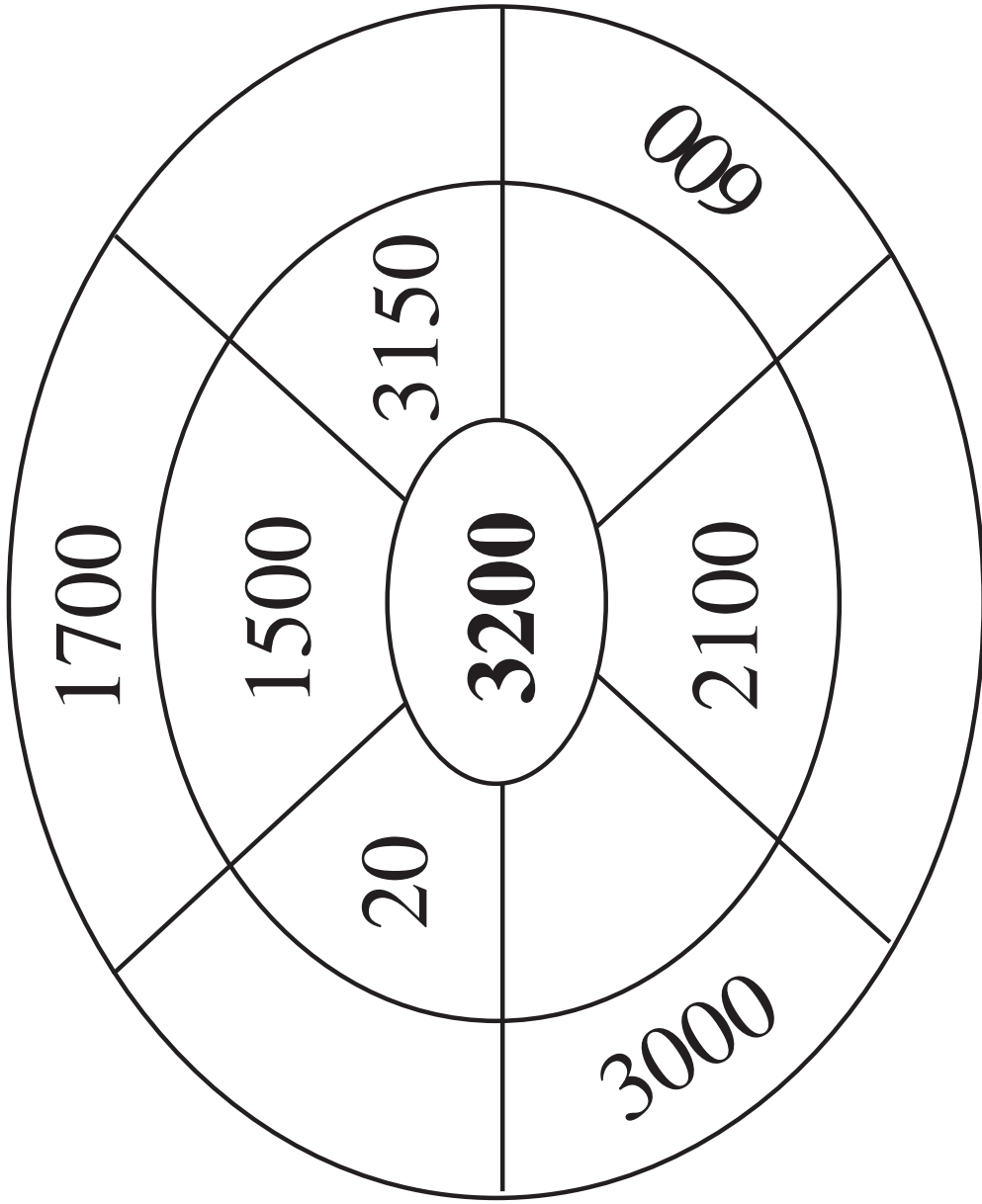

b)

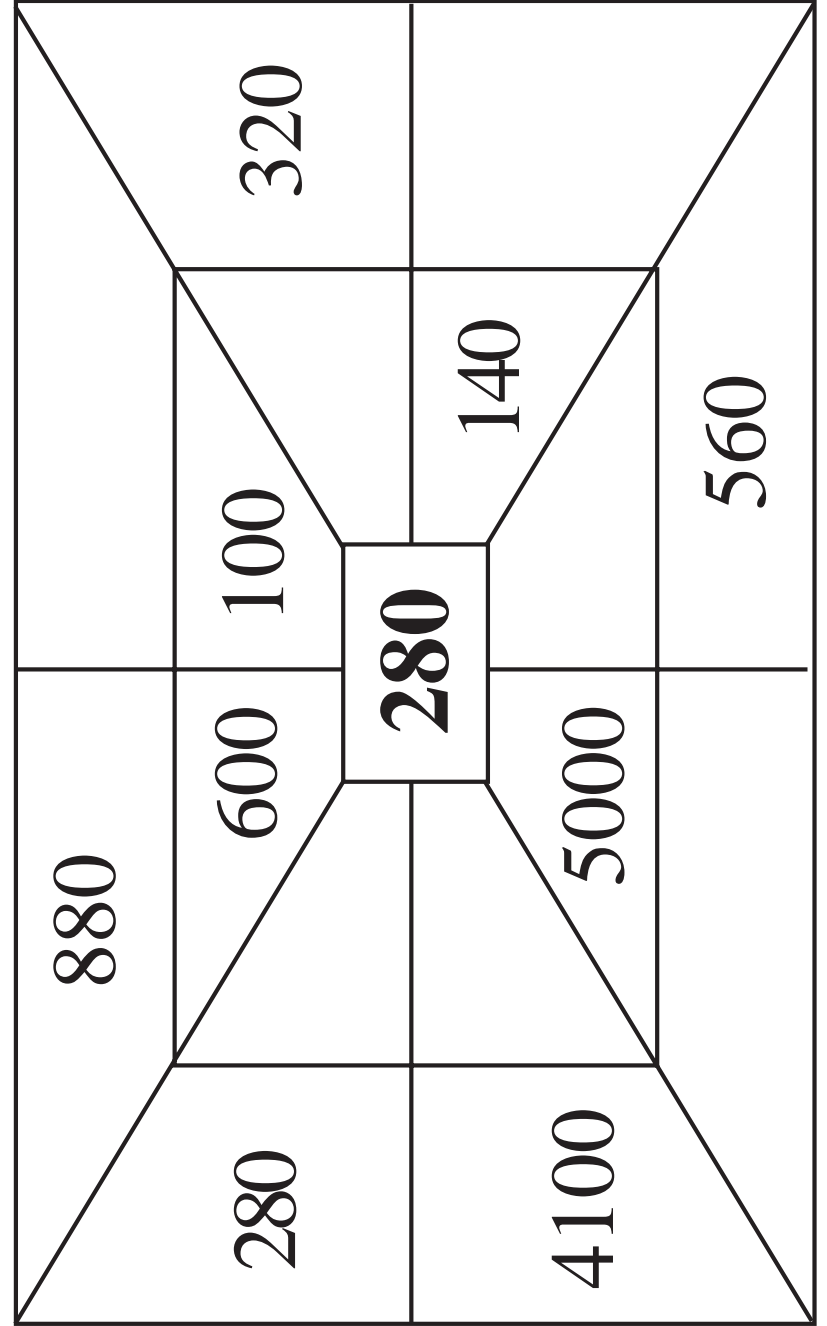

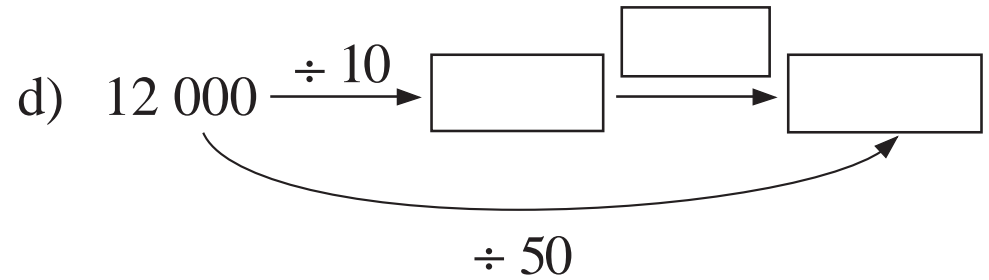
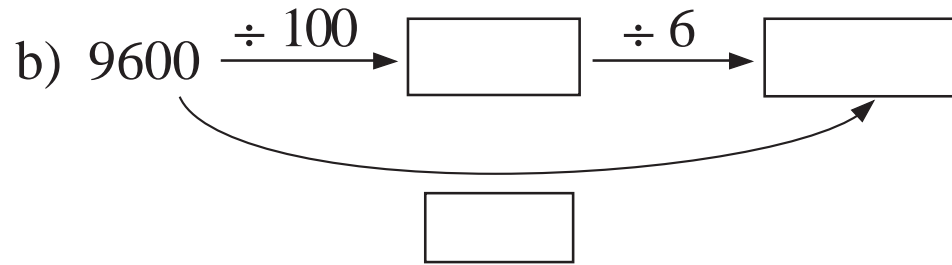
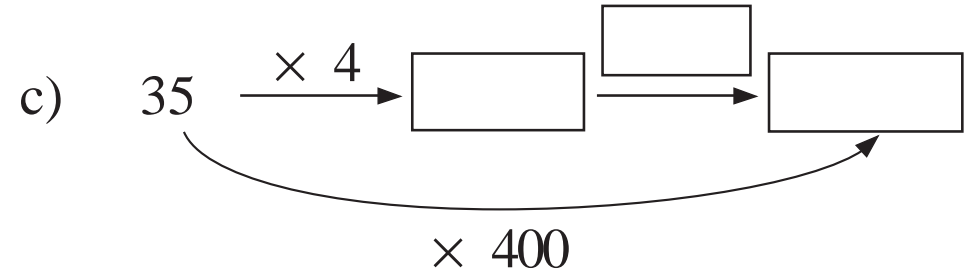
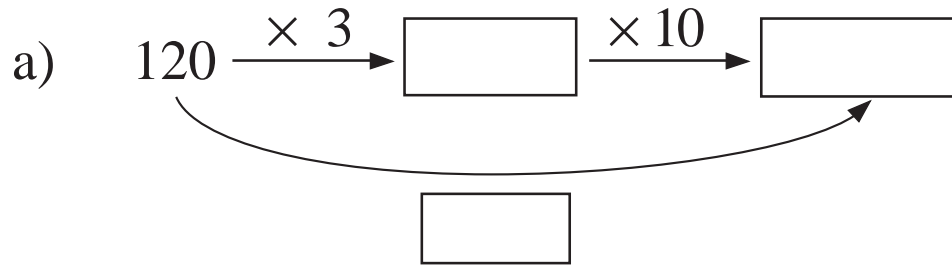

a) $27 \times 100 = 270 \times \square$

$$49 \times 100 = 4900 \times \square$$

$$60 \times 100 = 1000 \times \square$$

$$34 \times 100 = 10 \times \square$$

$$92 \times 100 = 920 \times \square$$

b) $130 \times 100 = 13 \times \square$

$$19 \times 1000 = 1900 \times \square$$

$$160 \times 100 = 10 \times \square$$

$$20 \times 1000 = 100 \times \square$$

$$17 \times 1000 = 170 \times \square$$

i) $2351 \times 6 =$

E:

--	--	--	--	--	--	--	--	--	--	--	--

C:

	2	3	5	1
			×	6

ii) $1278 \times 7 =$

E:

--	--	--	--	--	--	--	--	--	--	--	--

C:

	1	2	7	8
			×	7

C:

4	8	6	5	4

E:

Check:

			×	4
			+	

u	1	2	5	15	4	7		130	350		5000	3700	
v	1	1	3	4	5		50	17		2200	1		1059
w	3	5	13	34		20	70		800	5000		7400	1059

Rule: $w =$

$v =$

$u =$

LP 62/3

f)

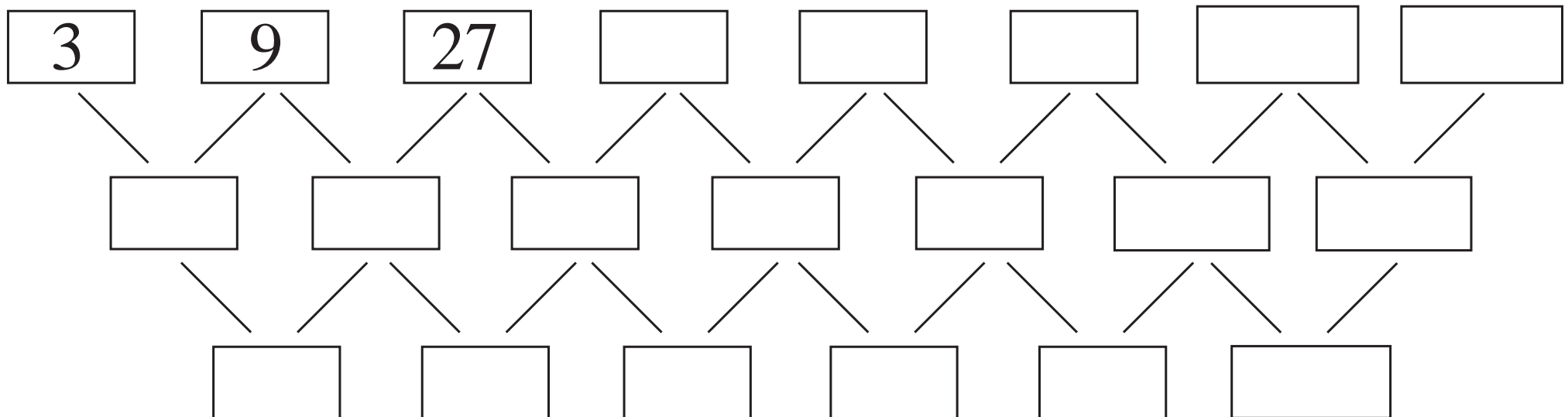

LP 63/2f

a)

<i>a</i>	3	400	2018	500		443		1		
<i>P</i>	12	1600	8072		360		6160		2800	0

LP 63/1a

b)

<i>a</i>	2	40	360	5	1100		5400		220	
<i>b</i>	3	80	440	8		122	600	1300		450
<i>P</i>	10	240	1600		6000	400		5200	440	902

LP 63/1b

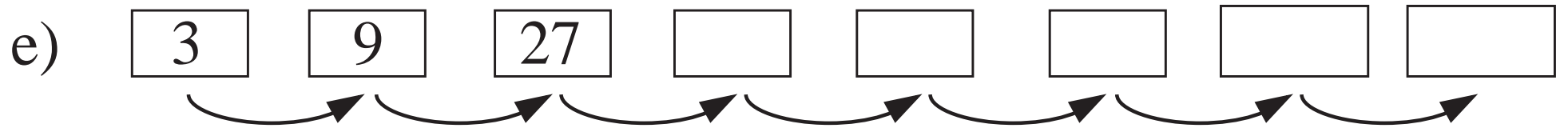
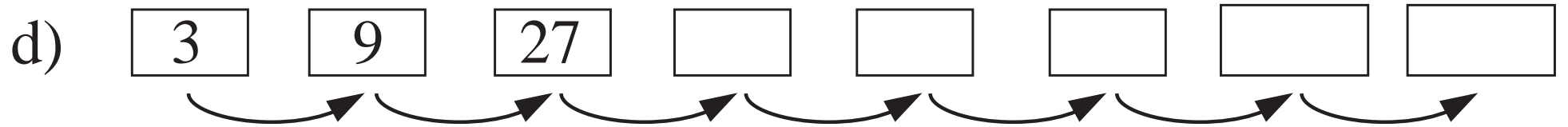
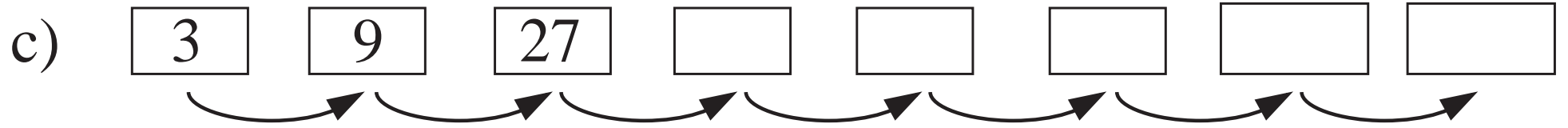
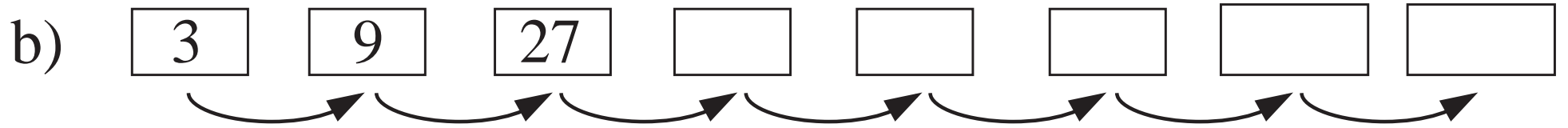
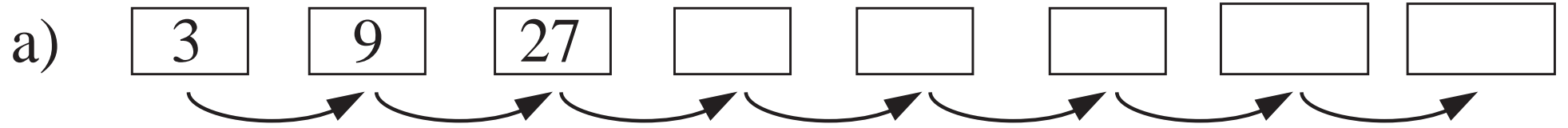

a)

x	1	2	3	4	5	20	6		8		10	30	40		
y	2	5	10	17	26	401		50		82				10 001	1

b)

u	4	1	10	100	2	3	7	21			16	1000	150
v	23	8	53	503					43	48			

a)

		8	9	7
			×	6

		5	0	7
			×	9

		5	1	6
			×	8

		4	7	6
			×	7

b)

	3	1	0	6
			×	3

	4	0	5	7
			×	2

	1	3	5	6
			×	7

	5	6	3	4
			×	5

LP 64/5

$$28 \times 100$$

$$208 \times 100$$

$$36\,000 \div 10$$

$$2080 \times 10$$

$$4280 \times 10$$

$$280 \times 10$$

$$428 \times 100$$

$$470 \times 10$$

$$47 \times 100$$

$$360 \times 10$$

$$2080$$

$$208 \times 10$$

LP 65/2

a)

3	6	7	8	

3	3	4	7	2

6	3	8	5	6

Checks:

b)

5	4	9	7	

7	6	0	2	

7	4	0	3	6

$$2000 < n < 2020$$

A Multiple of 3

B Divisible by 5

a) $45 \xrightarrow{+37} \boxed{} \xrightarrow{\text{Oval}} 12 \xrightarrow{+320} \boxed{} \xrightarrow{+127} \boxed{} \xrightarrow{\text{Oval}} 491$

b) $5093 \xrightarrow{-410} \boxed{} \xrightarrow{\text{Oval}} 4760 \xrightarrow{+1050} \boxed{} \xrightarrow{-2205} \boxed{} \xrightarrow{\text{Oval}} 8000$

c) $75 \xrightarrow{\div 3} \boxed{} \xrightarrow{\text{Oval}} 100 \xrightarrow{\times 80} \boxed{} \xrightarrow{\div 20} \boxed{} \xrightarrow{\text{Oval}} 6000$

d) $400 \xrightarrow{\div 8} \boxed{} \xrightarrow{\text{Oval}} 254 \xrightarrow{\times 2} \boxed{} \xrightarrow{\times 4} \boxed{} \xrightarrow{\text{Oval}} 1900$

a)

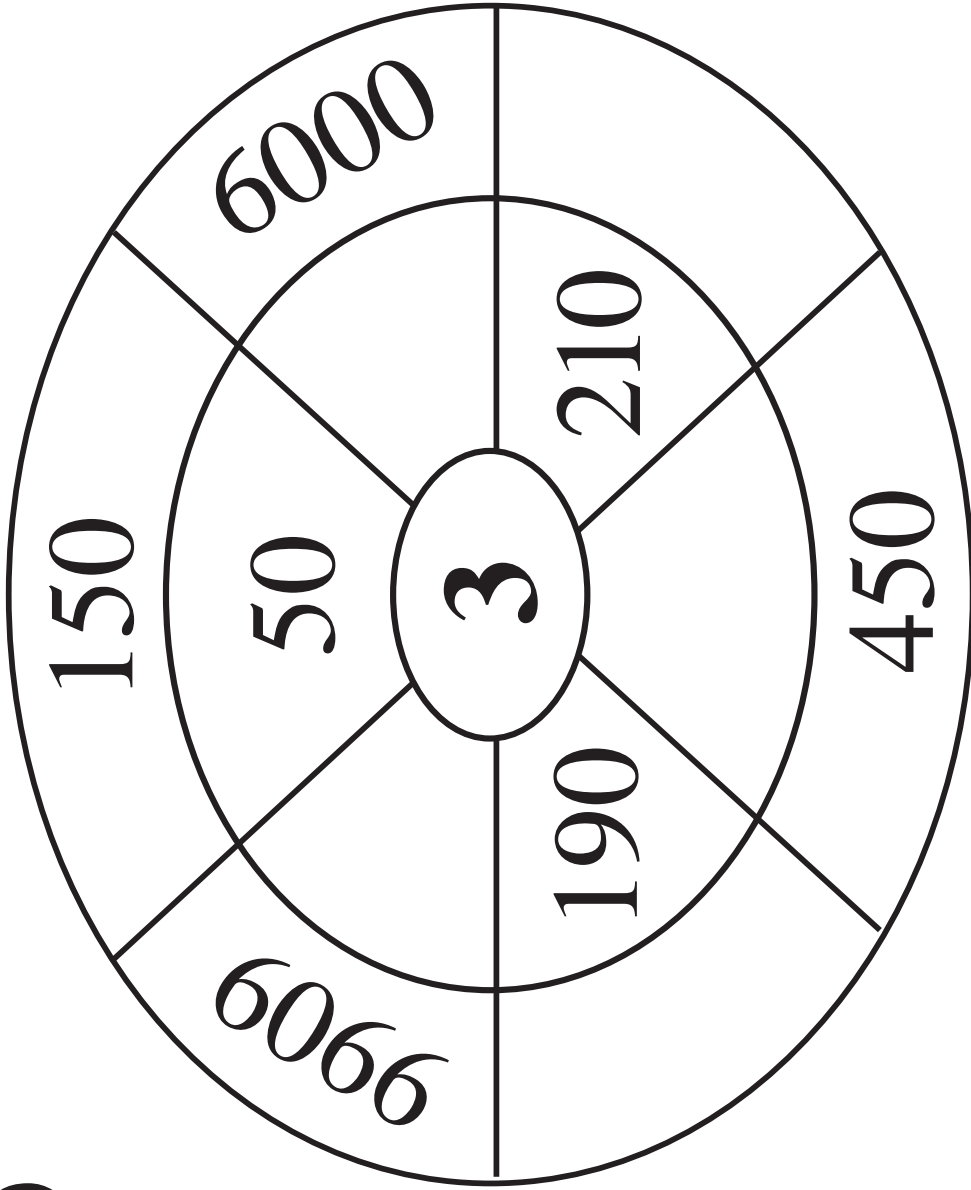

b)

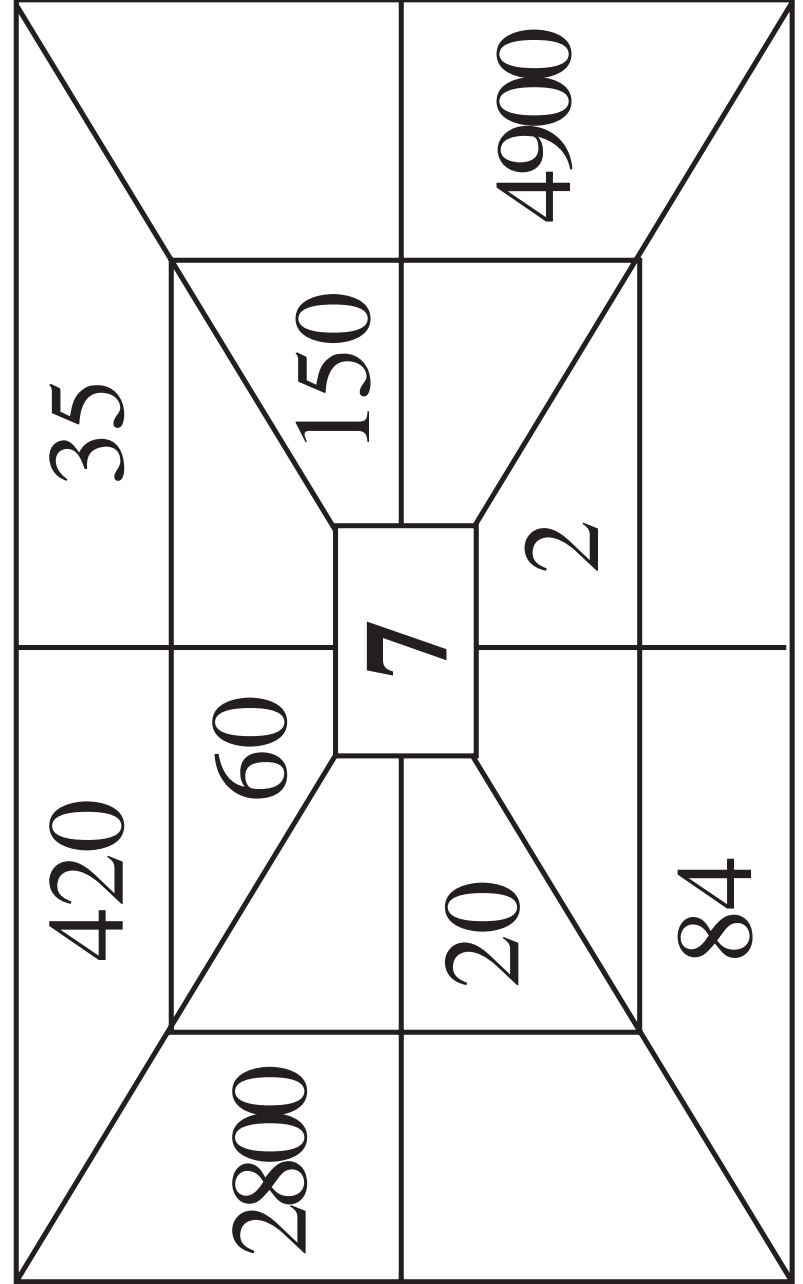

a)

		9	4	7
			×	3

	1	1	8	6
			×	8

	2	0	6	1
			×	5

	1	8	0	4
		×	1	0

b)

5	6	0	7	9

8	9	4	0	7

3	2	5	0	1

1	0	2	9	1

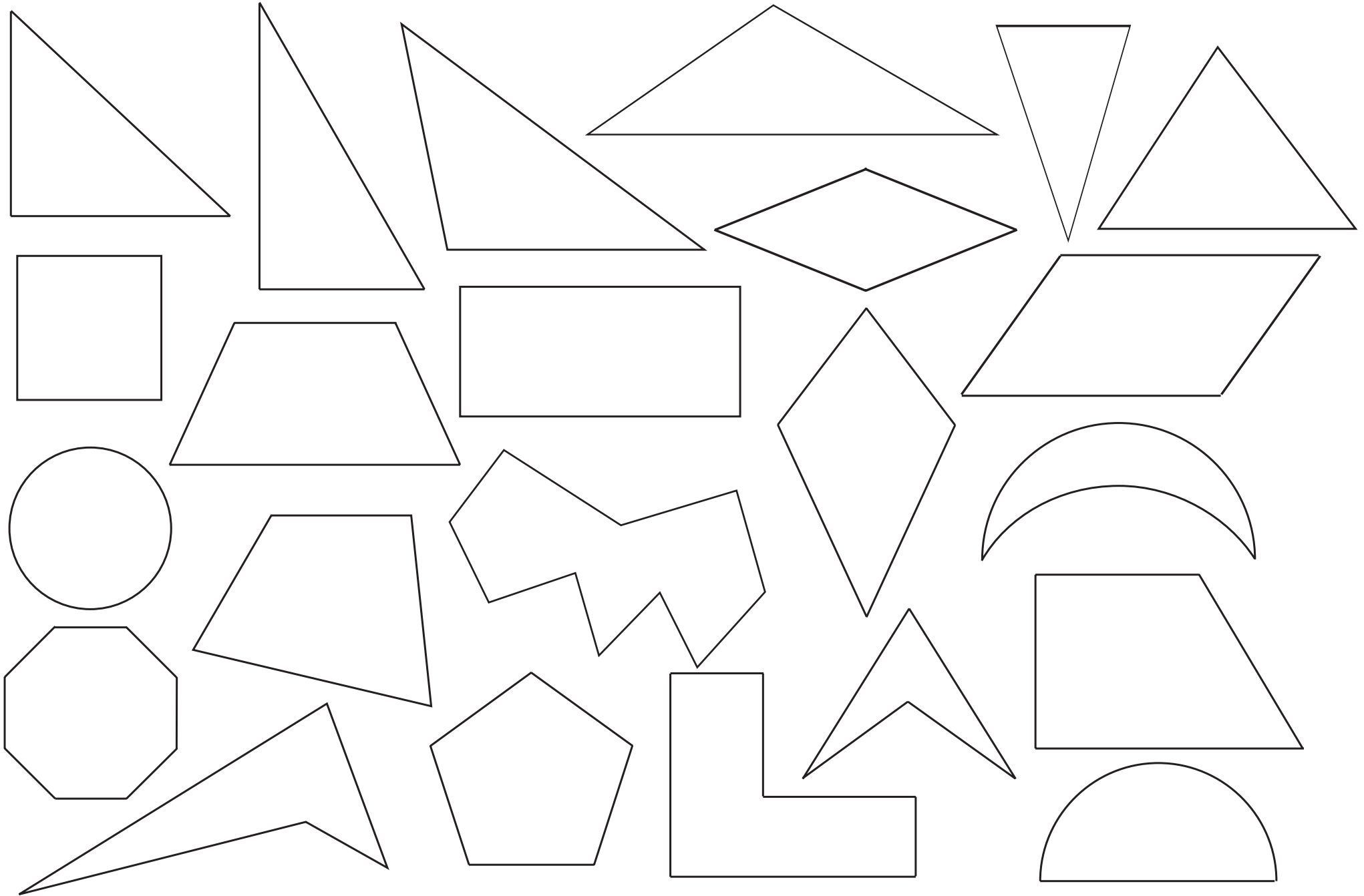

Journey	Distance on map	Real distance
$AB \approx$		
$AC \approx$		
$AD \approx$		
$BC \approx$		
$BD \approx$		
$CD \approx$		

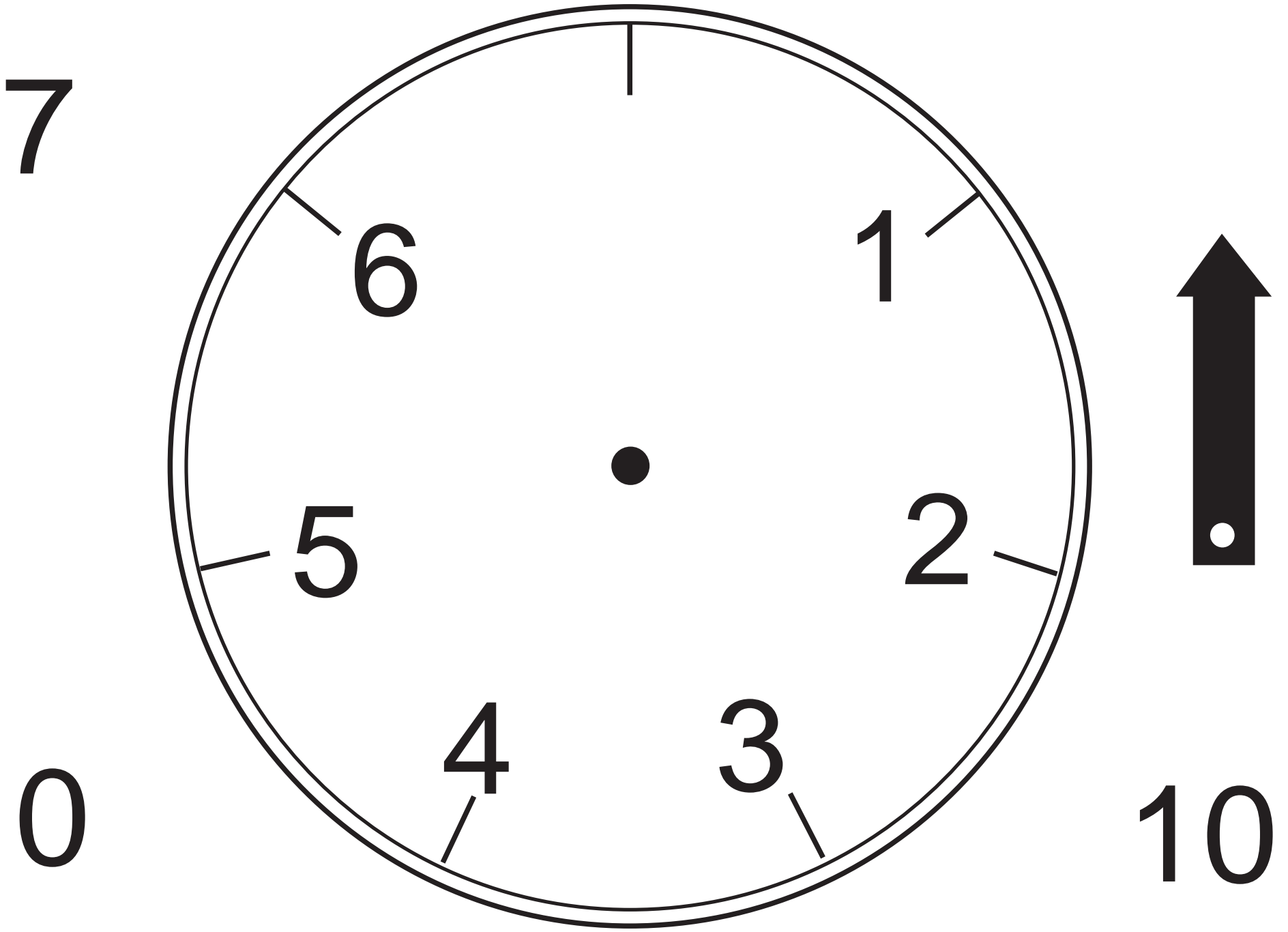

\Longrightarrow means $+ 2400$ and \longrightarrow means $- 300$

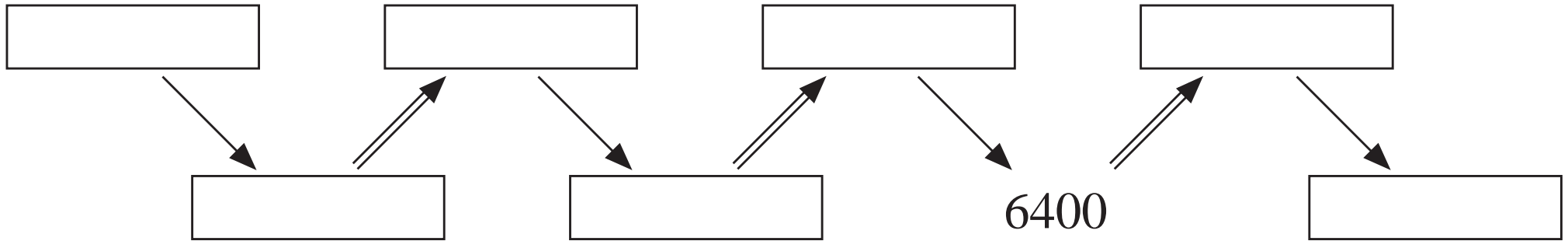

LP 68/3

a) i)

	3	4	3	6
+	5	3	4	2
<hr/>				

ii)

	5	6	7	8
+	4	2	8	1
<hr/>				

iii)

	3	7	0	5
+	4	1	3	8
<hr/>				

iv)

	3	7	1	6
+	8	3	9	5
<hr/>				

b) i)

	6	5	2	8
-	2	4	0	5
<hr/>				

ii)

	4	1	7	3
-	1	0	4	6
<hr/>				

iii)

	7	0	5	9
-	4	2	6	5
<hr/>				

iv)

1	2	3	4	5
-	3	4	2	9
<hr/>				

a)

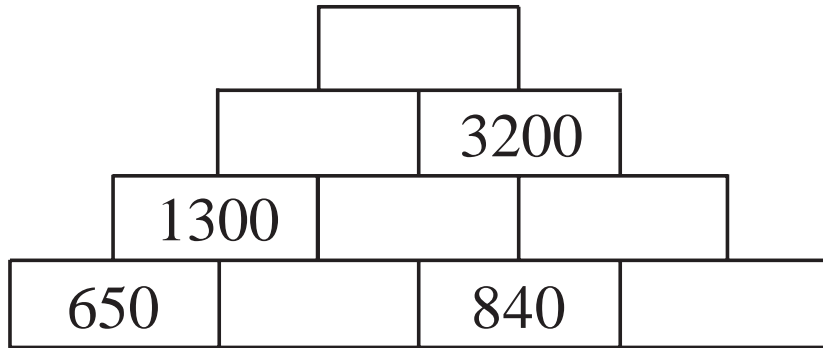

b)

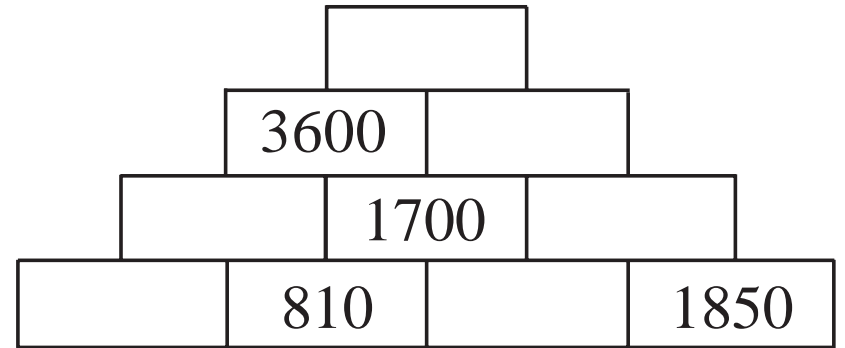

LP 68/5

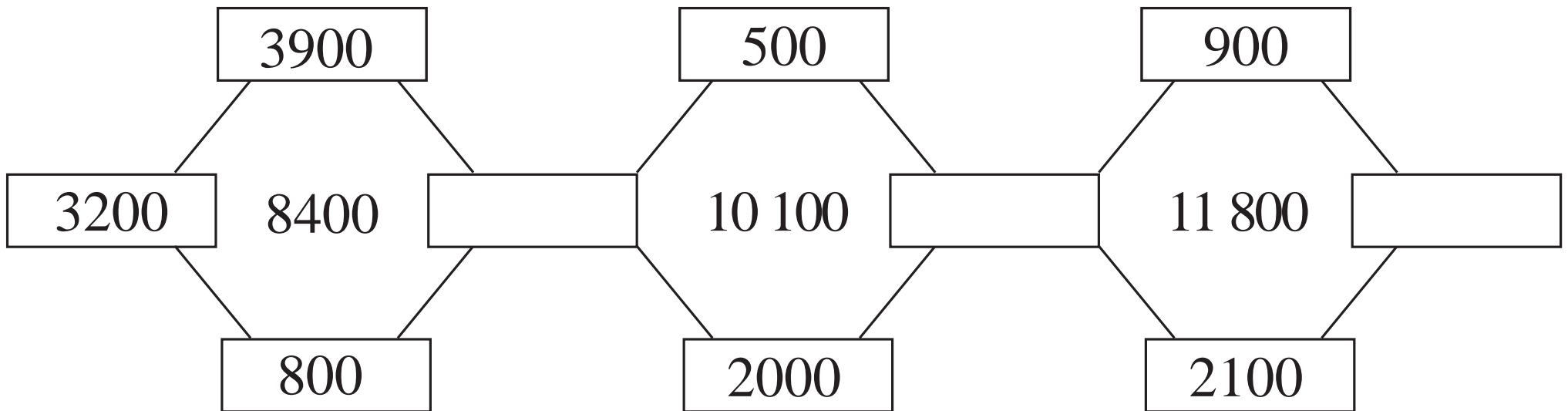

LP 69/5

a) $697 \times 3 + 802 \times 8$

$697 \times 8 - 802 \times 3$

b) $268 \times 7 + 144 \times 9$

$268 \times 9 - 144 \times 7$

c) $2357 \times 6 - 469 \times 4$

$2357 \times 4 + 469 \times 6$

a)

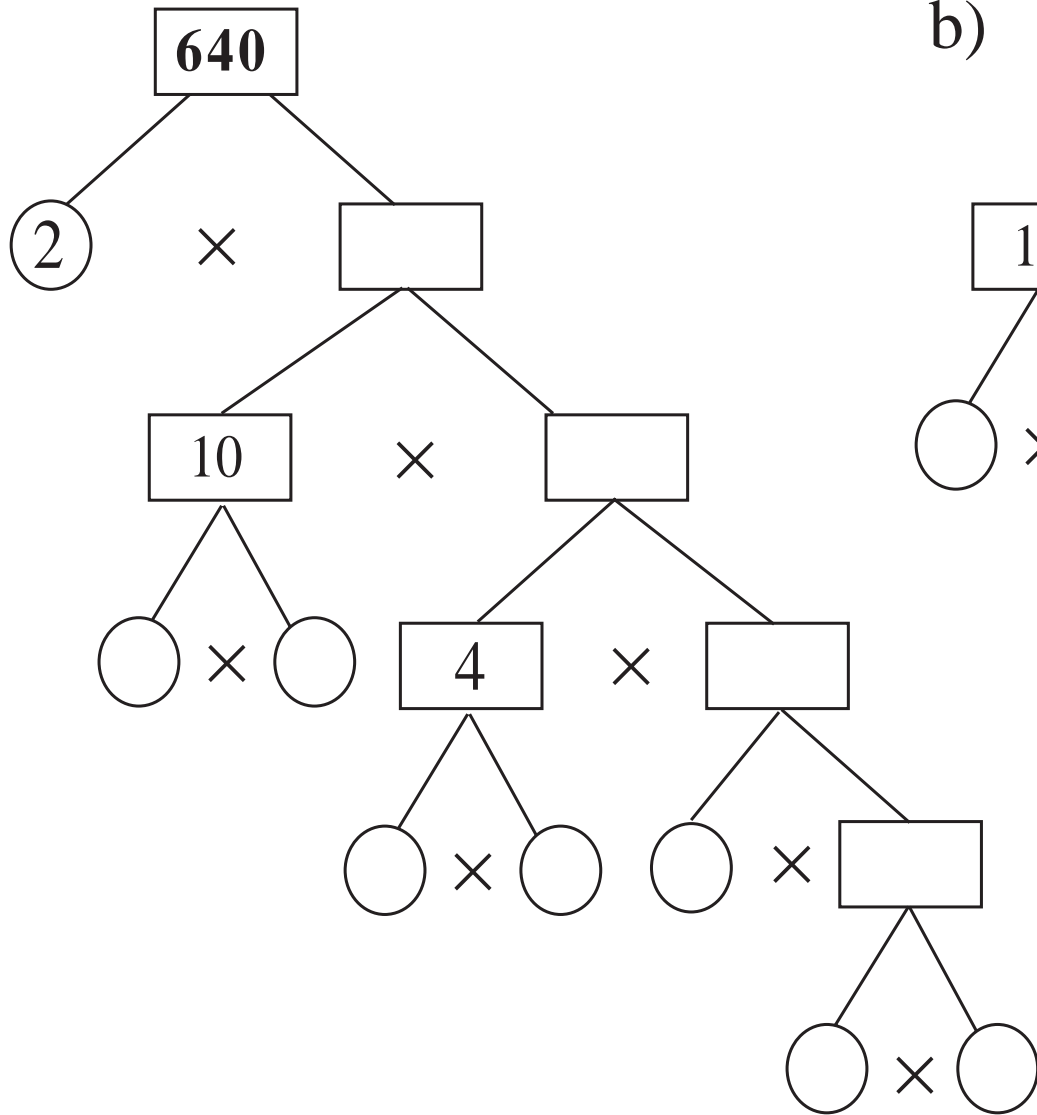

b)

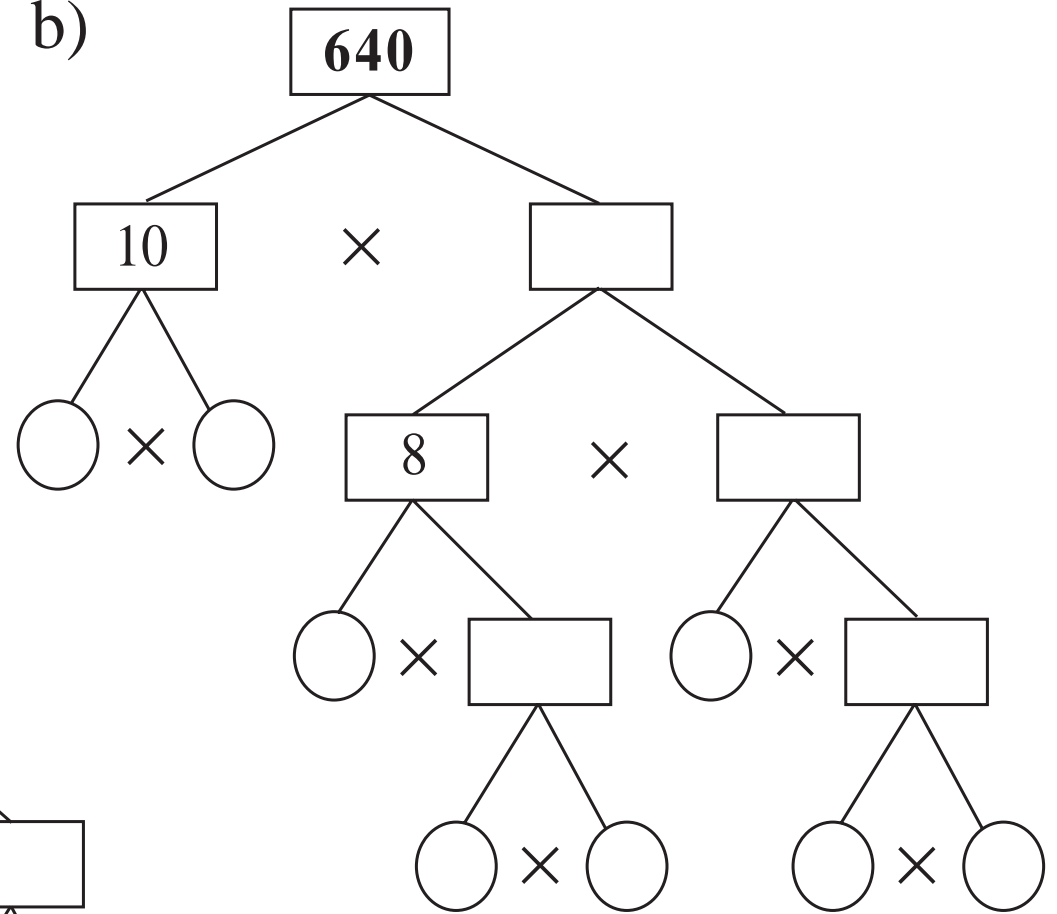

a) i)

1	1	9	5
		×	5

ii)

3	0	1	8
		×	3

iii)

1	2	5	1
		×	6

iv)

	2	1	6	8
			×	9

b) i)

4	8	0	6	0

ii)

7	9	7	2	6

iii)

6	4	4	4	4

iv)

8	1	2	8	6	4

a)

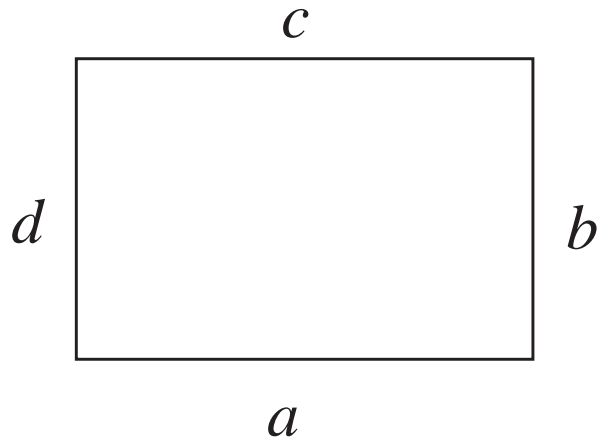

b)

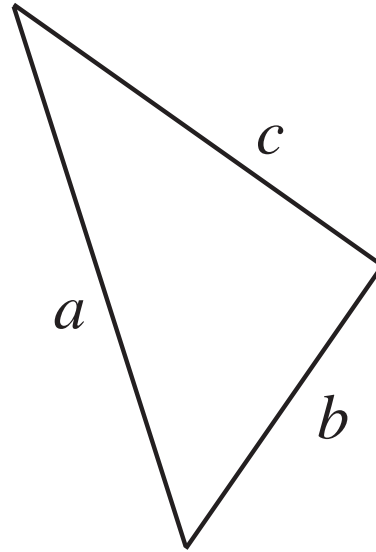

c)

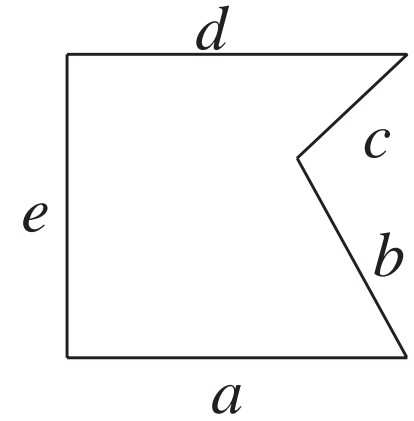

d)

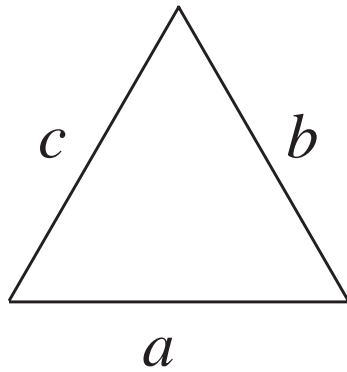

e)

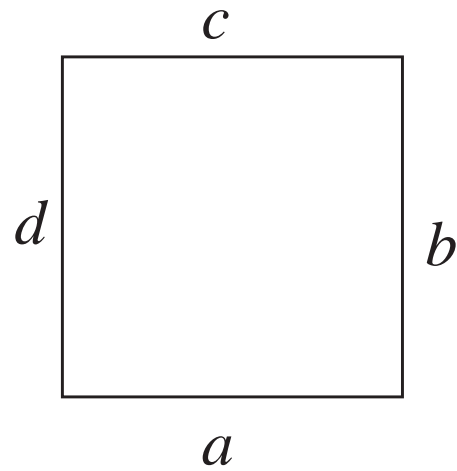

f)

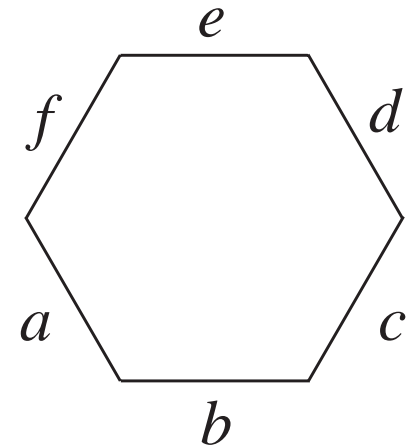

a)

1	2	6	7	8
		8	5	2
<hr/>				

b)

5	8	1	6
	4	2	5
1	3	4	8
		3	7
<hr/>			

c)

3	7	1	6
	1	5	7
<hr/>			

d)

1	0	0	0	0
	5	7	6	8
<hr/>				

e)

1	0	1	0	1
		9	9	9
<hr/>				

f)

	8	7	9
		×	6
<hr/>			

g)

	1	7	0	9
			×	4
<hr/>				

h)

7	8	0	3	2
<hr/>				

i)

8	5	6	0	3

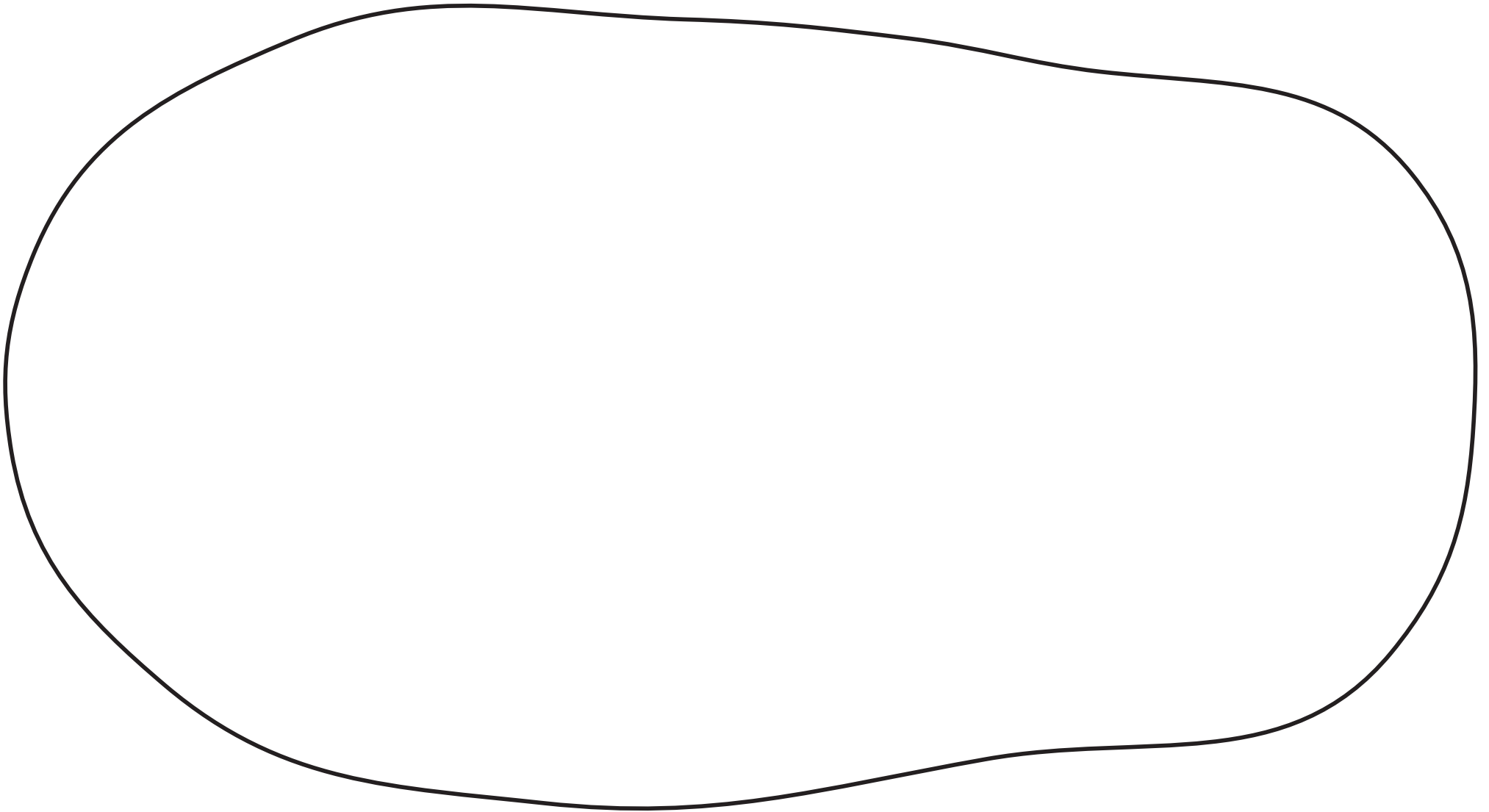

a	780	1000	2813	0	5000		1
b	40	400	1000	0		315	1
$c = 2 \times a + b$					10 723	8315	

LP 73/2

a) $3060 \bigcirc 3006$

b) $80 \bigcirc 8000 \div 10$

c) $21\,306 \bigcirc 21\,406 - 100$

d) $476 \times 2 \bigcirc 320 \times 3$

e) $32\,178 \bigcirc 22\,178 + 1001$

f) $8.5 \bigcirc 9 - \frac{1}{2}$

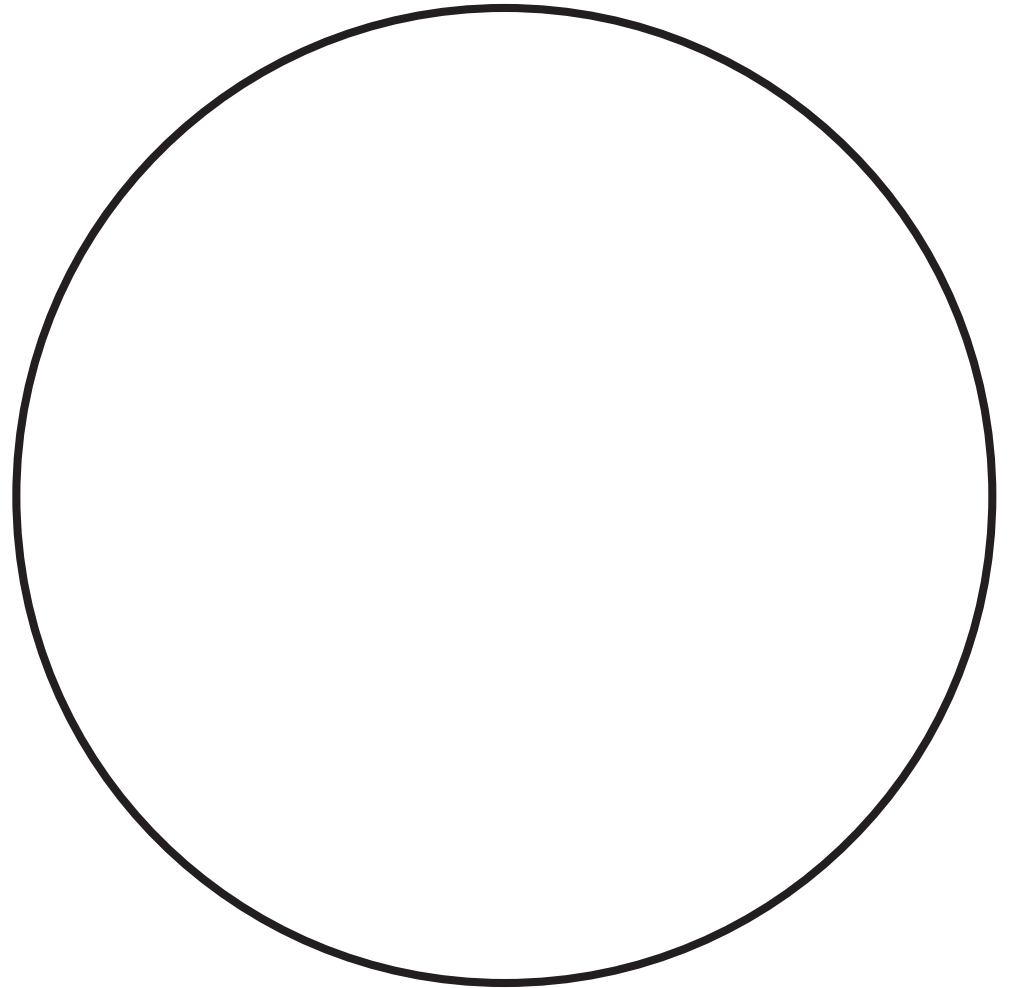
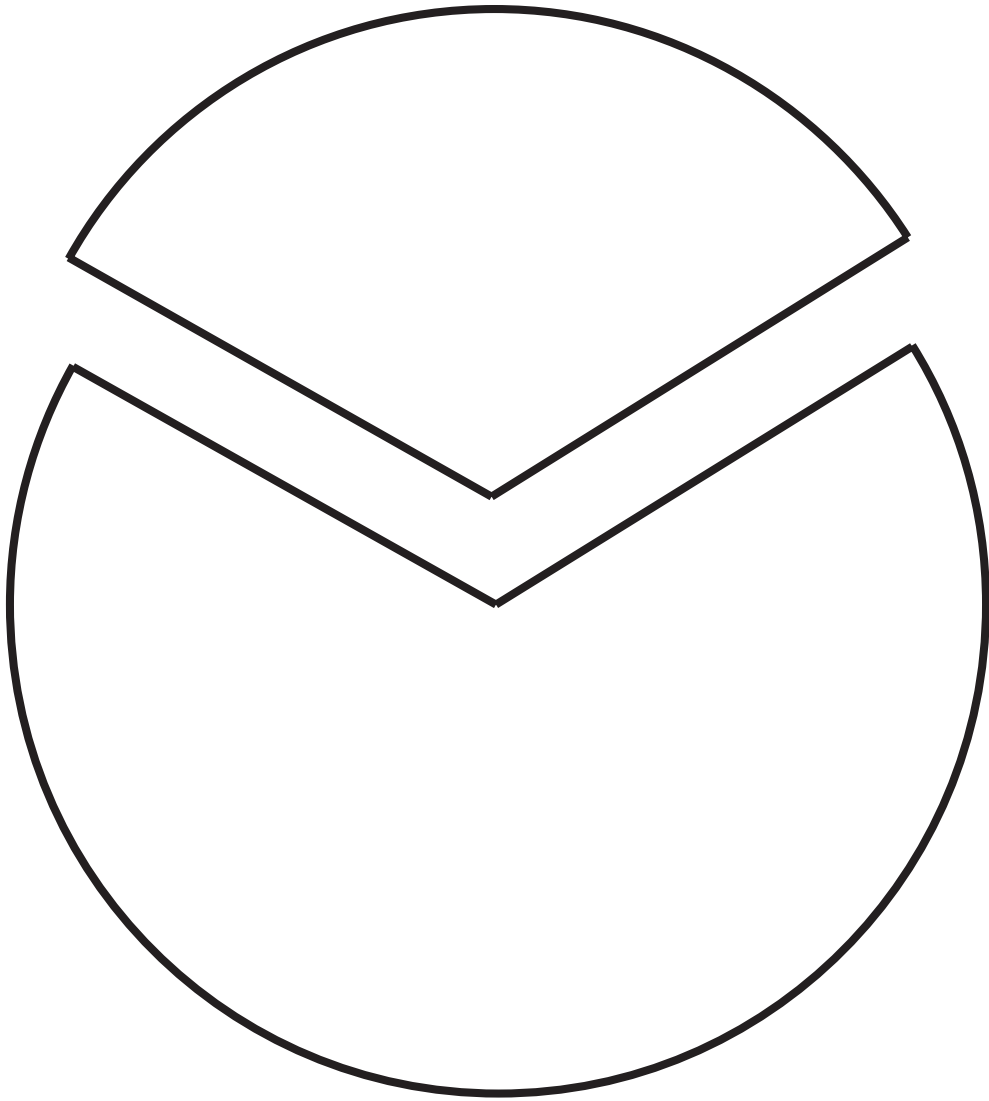

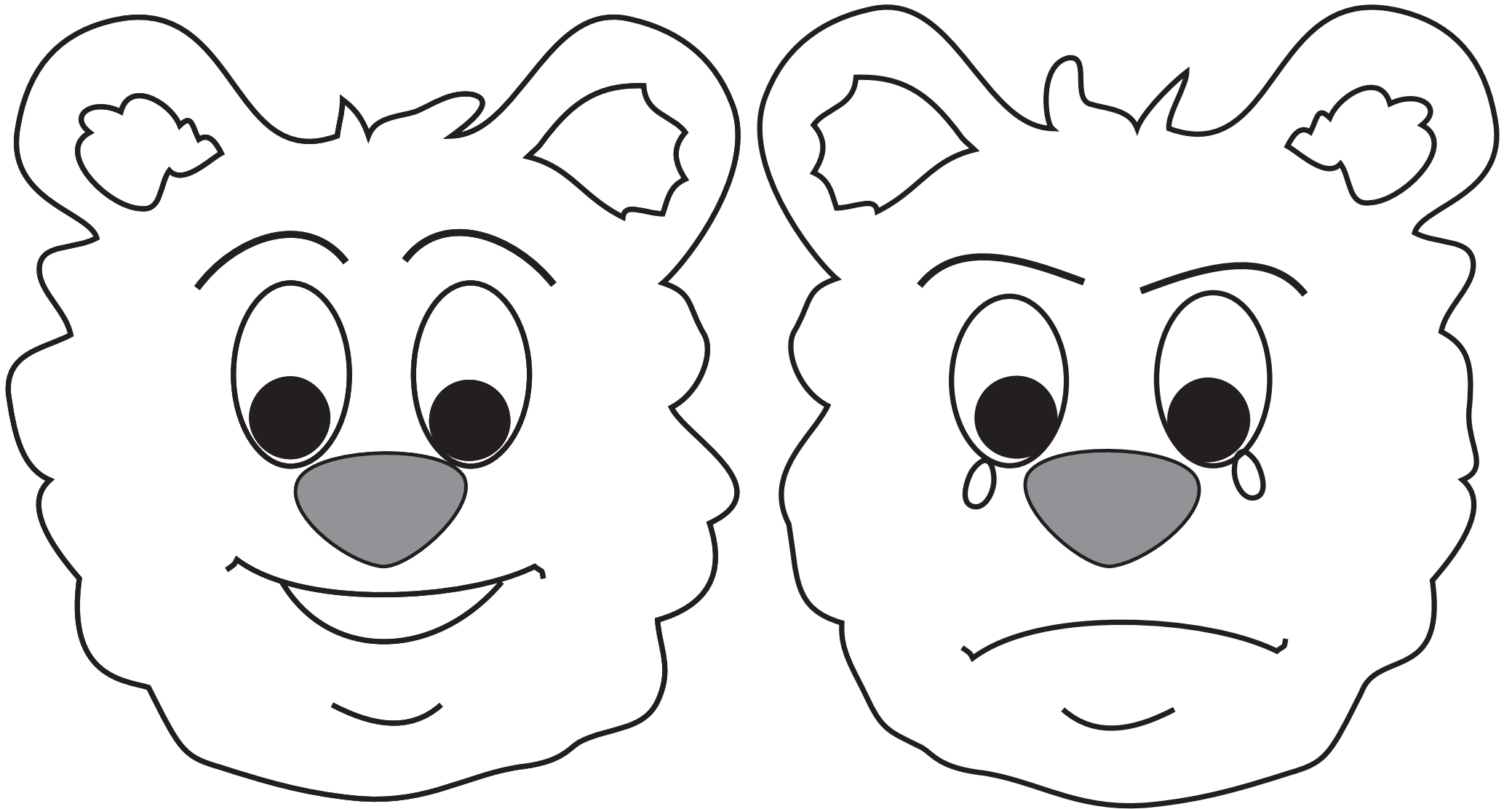

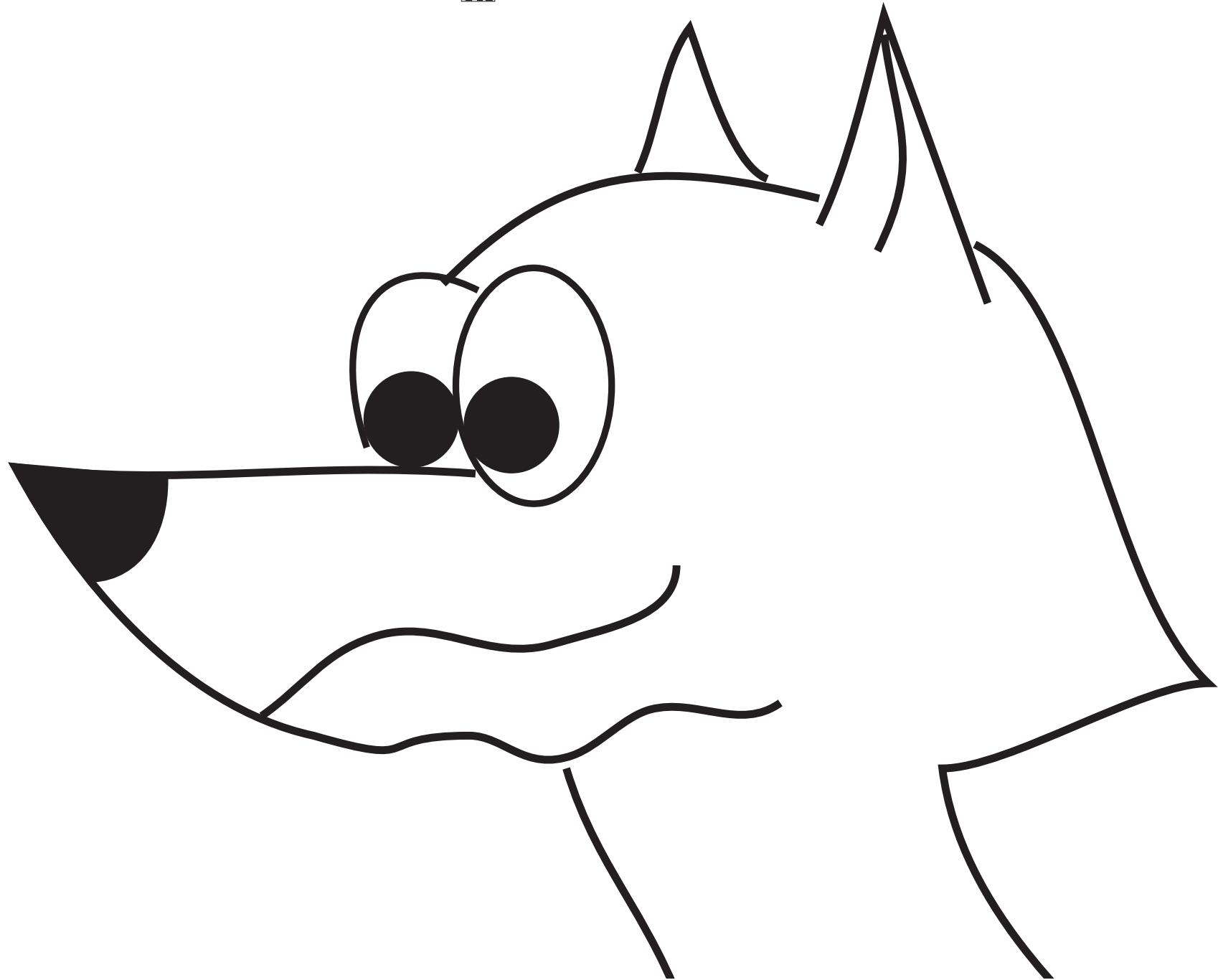



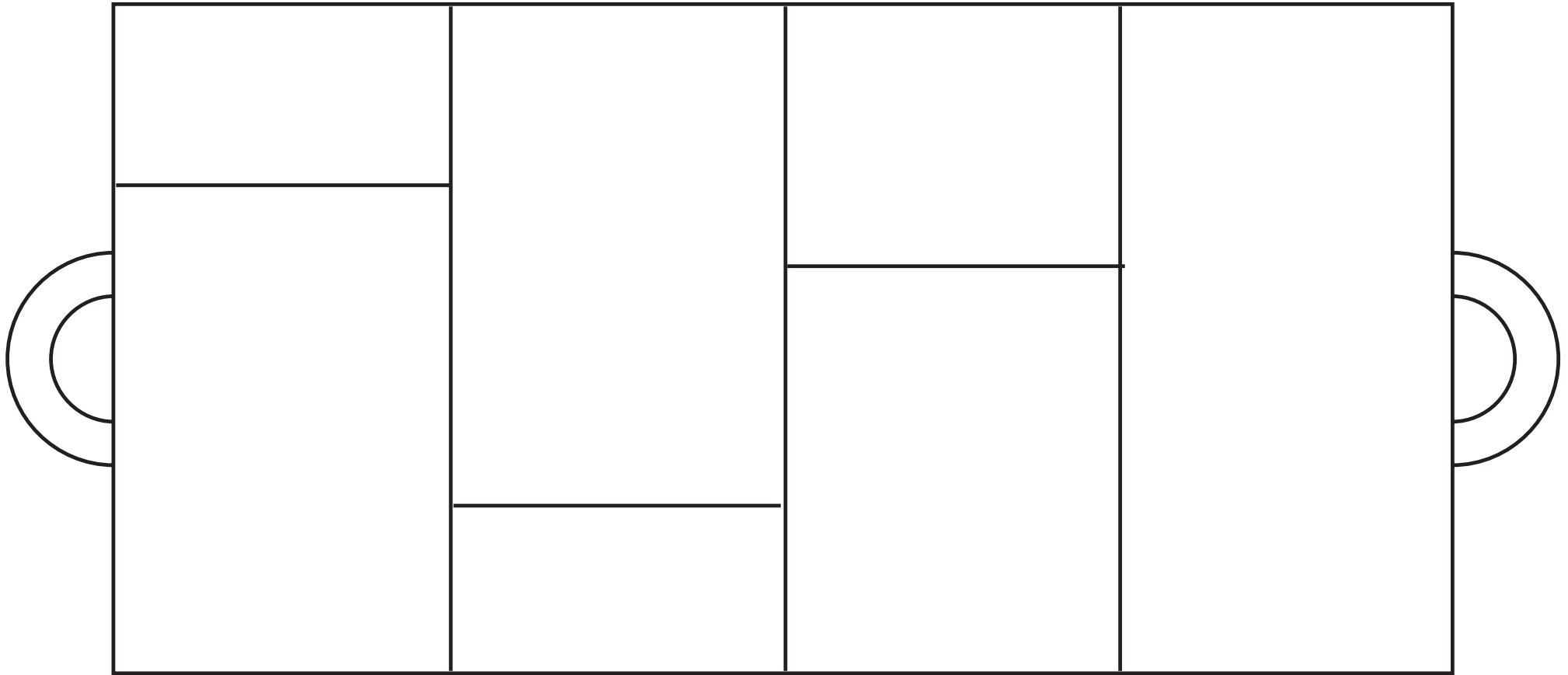

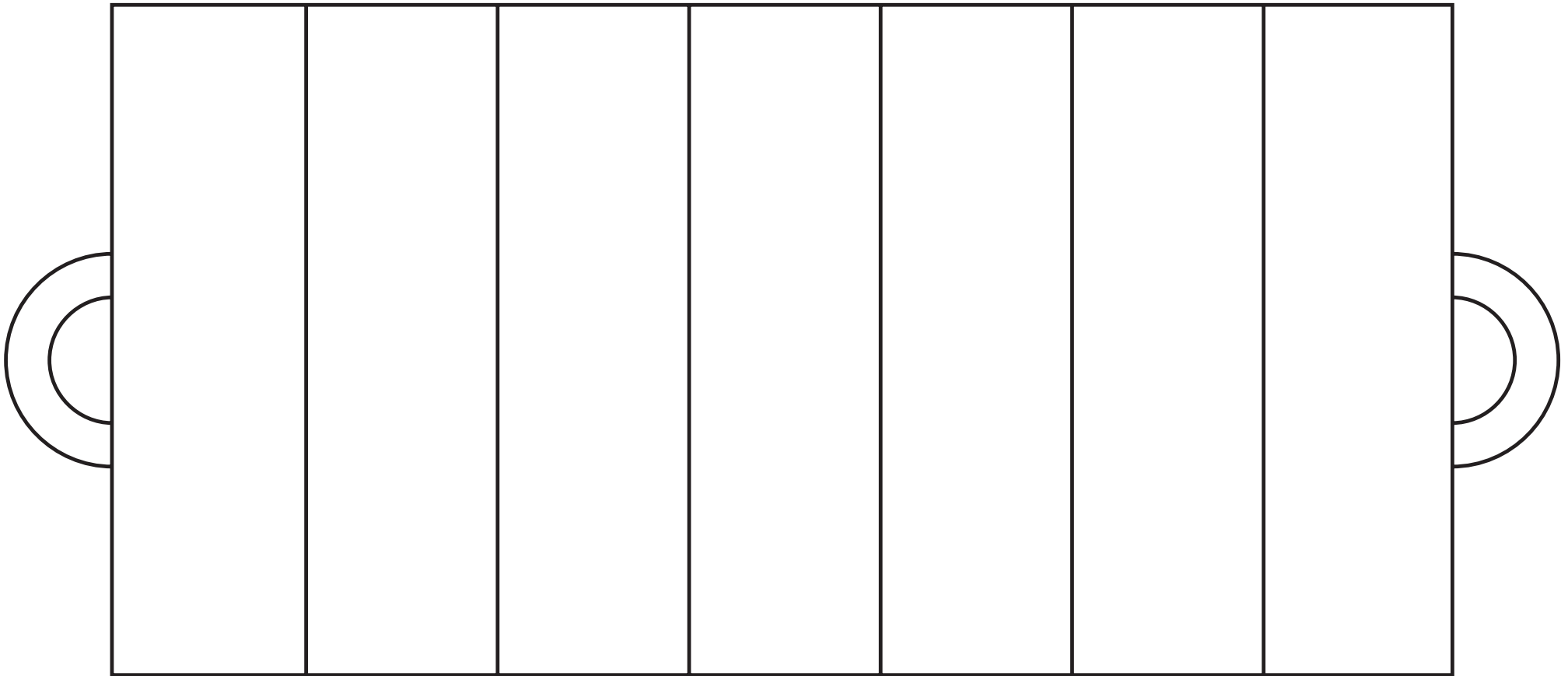

Make 4 copies



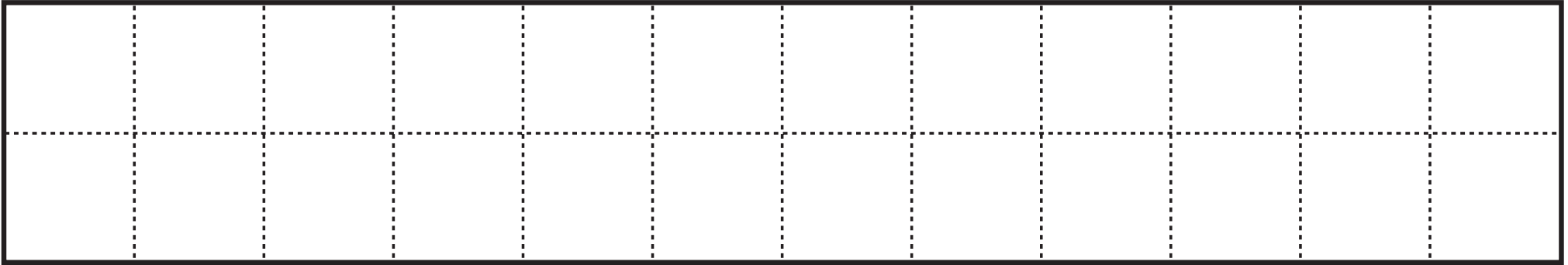

LP 76/3b

a)

b)

c)

d)

e)

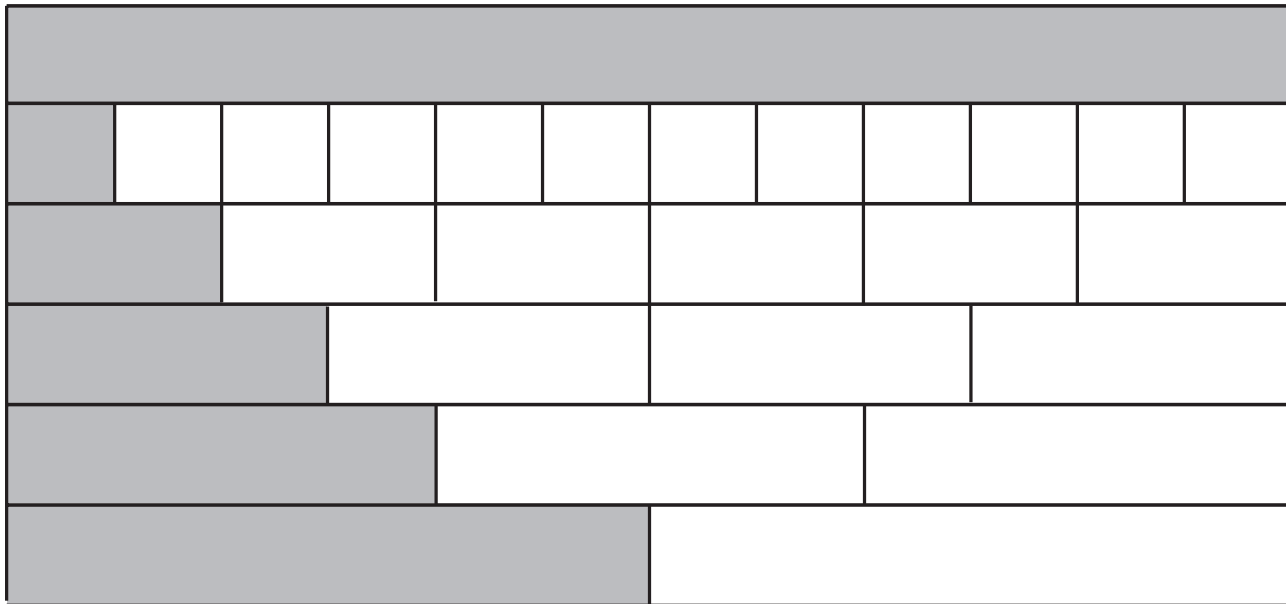



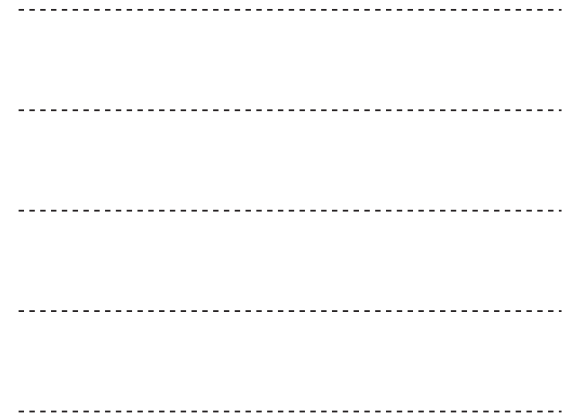



1 unit



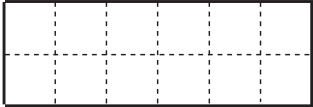

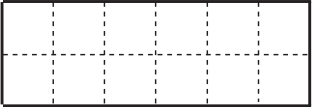

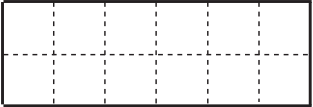

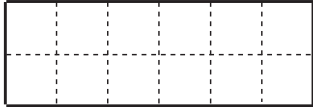

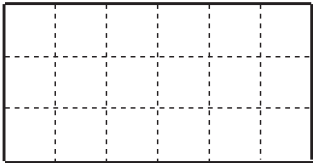

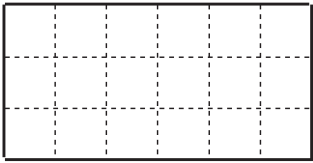

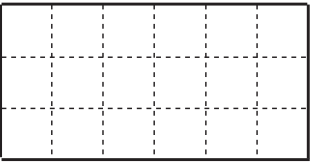
a) $\frac{1}{2}$ ○ $\frac{1}{3}$ ○ $\frac{1}{4}$ ○ $\frac{1}{6}$

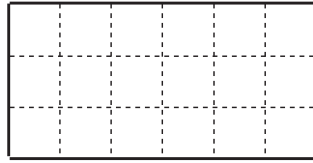

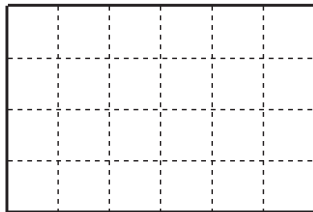

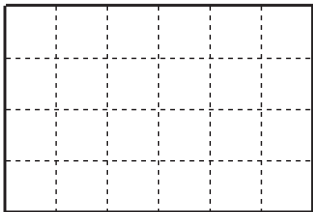

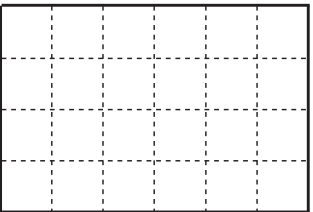
b) $\frac{1}{18}$ ○ $\frac{1}{9}$ ○ $\frac{1}{6}$ ○ $\frac{1}{3}$

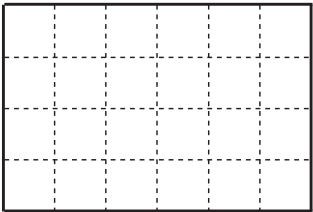
c) $\frac{1}{5}$ ○ $\frac{1}{10}$ ○ $\frac{1}{15}$ ○ $\frac{1}{30}$

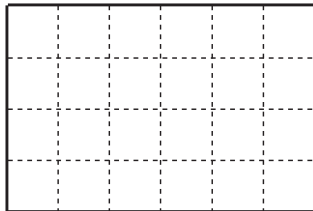
a) $\frac{1}{6}$   $\frac{2}{6}$   $\frac{3}{6}$   $\frac{4}{6}$ 

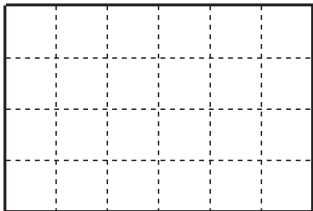
b) $\frac{1}{9}$   $\frac{2}{9}$   $\frac{3}{9}$   $\frac{4}{9}$ 

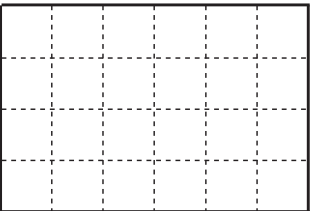
c) $\frac{4}{4}$   $\frac{3}{4}$   $\frac{2}{4}$   $\frac{1}{4}$ 

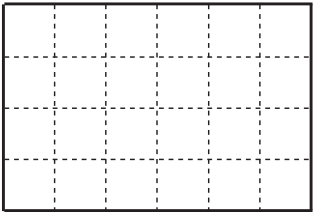
d) $\frac{8}{8}$   $\frac{6}{8}$   $\frac{4}{8}$   $\frac{2}{8}$ 



1 unit

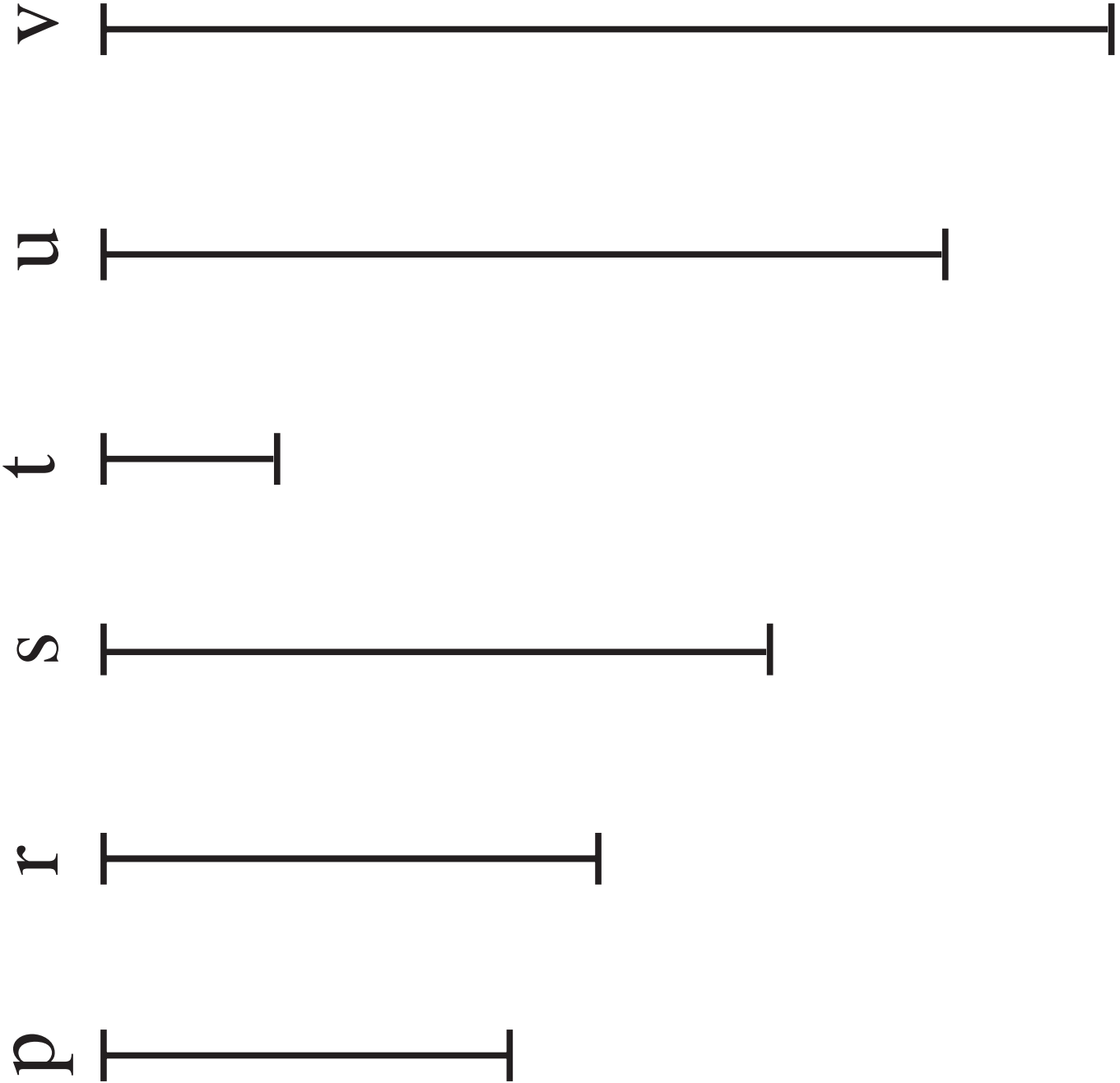

i)

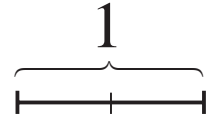
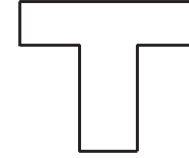
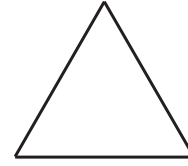
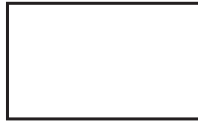
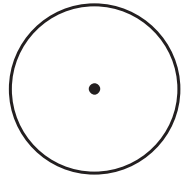

ii)

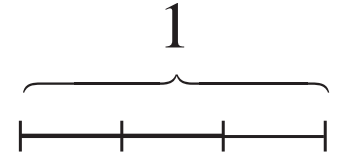
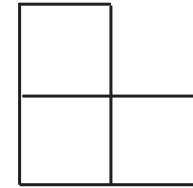
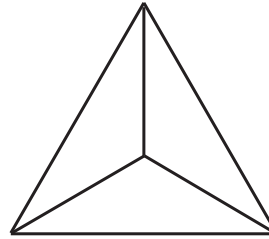
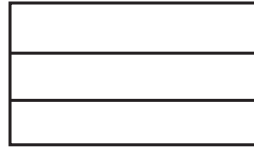

iii)

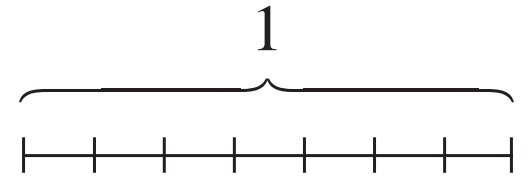
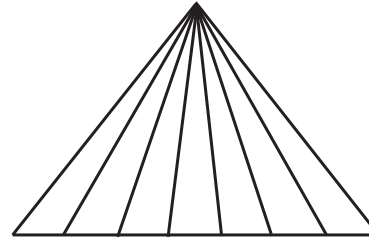
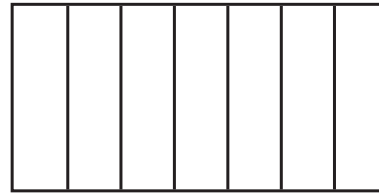
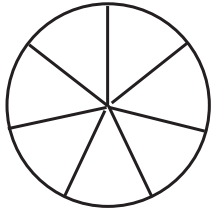

iv)

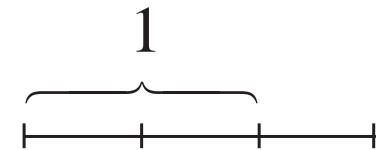
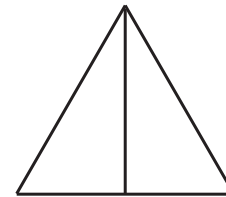
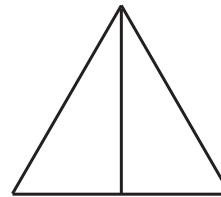
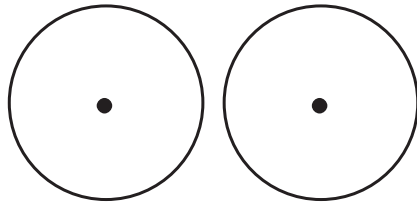

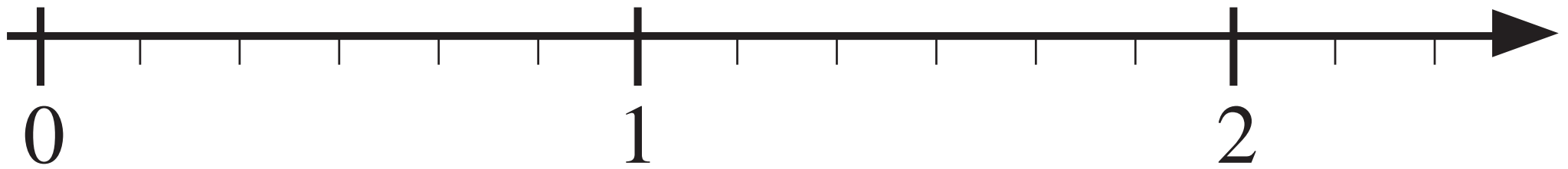



--	--	--	--	--	--	--	--	--	--	--	--	--	--	--	--	--	--	--	--

--	--	--	--	--	--	--	--	--	--	--	--	--	--	--	--	--	--	--	--

--	--	--	--	--	--	--	--	--	--	--	--	--	--	--	--	--	--	--	--

--	--	--	--	--	--	--	--	--	--	--	--	--	--	--	--	--	--	--	--



--	--	--	--	--	--	--	--	--	--

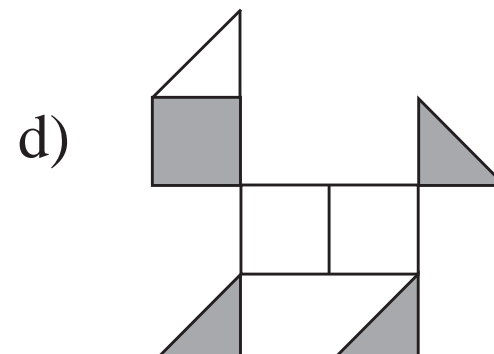
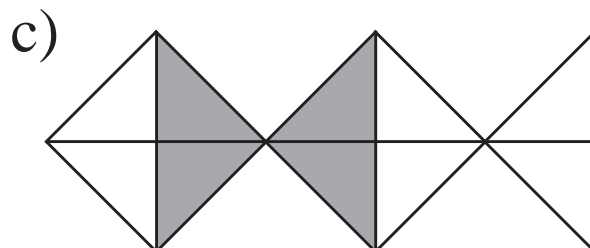
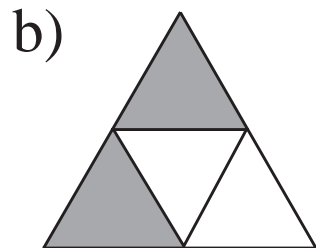
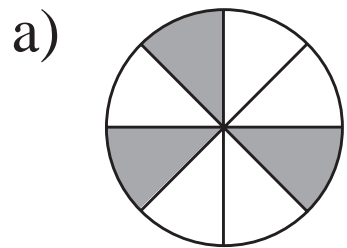

.....

.....

.....

.....

LP 77/4

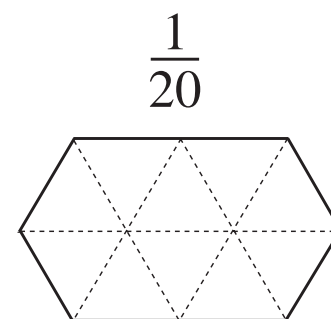
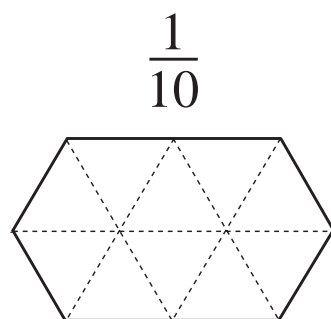
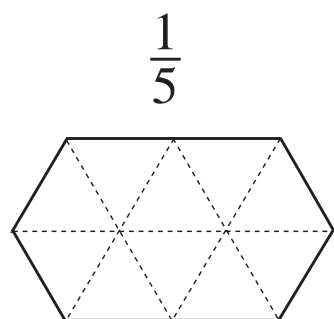
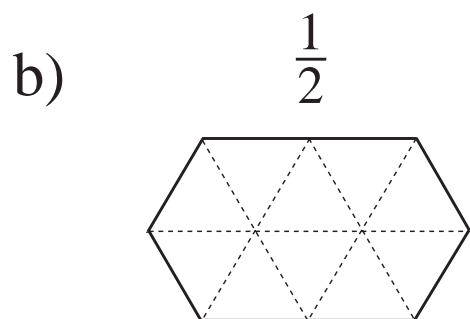
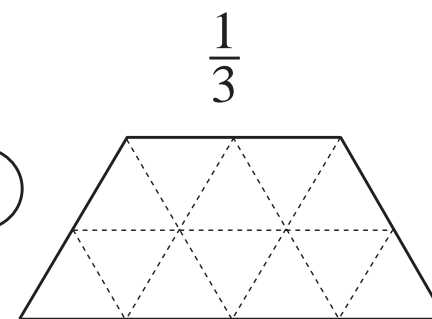
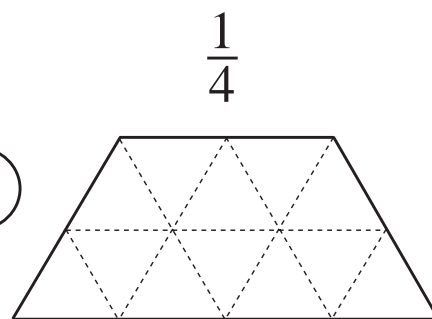
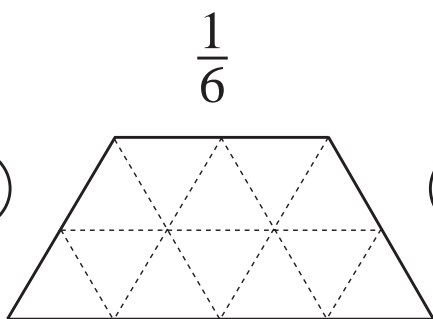
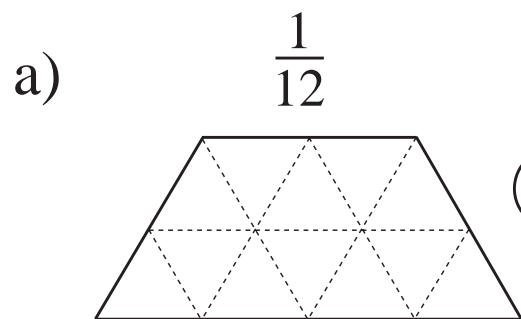

LP 77/5

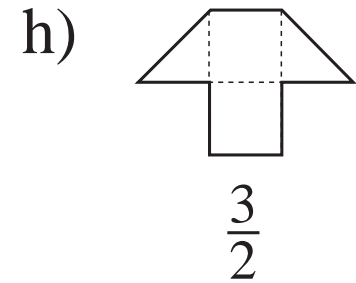
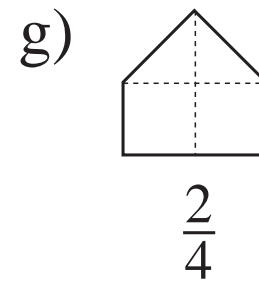
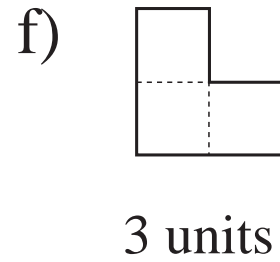
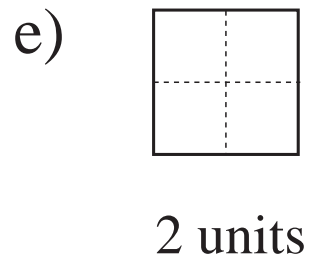
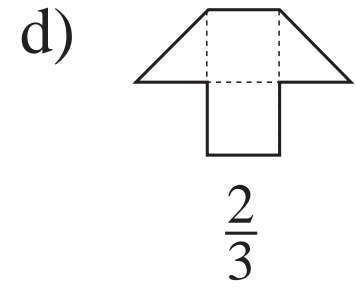
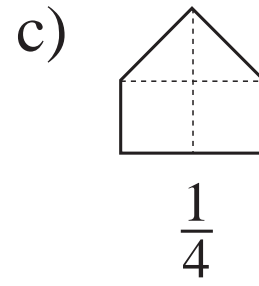
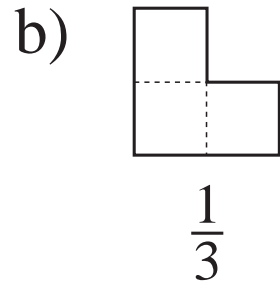
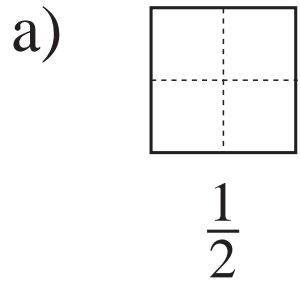



.....



.....

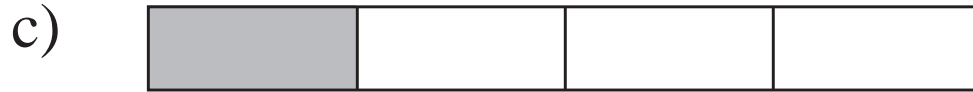

.....



.....



.....

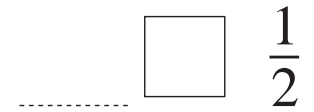
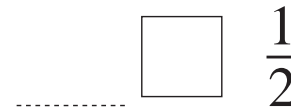
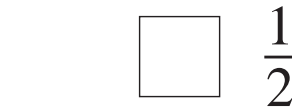
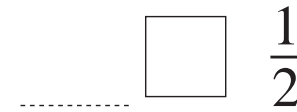
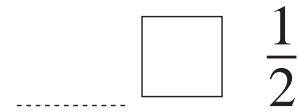
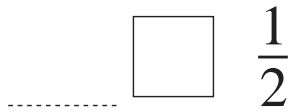
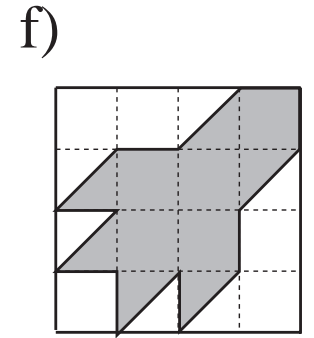
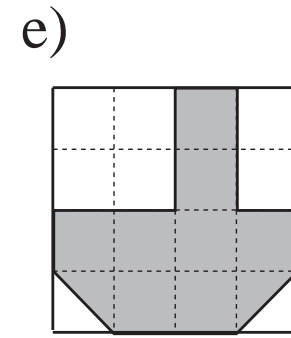
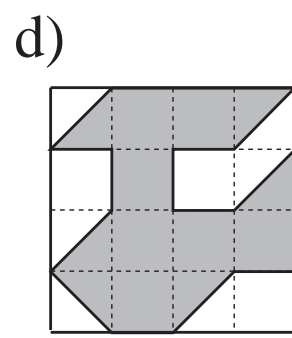
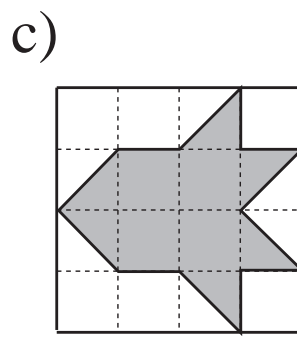
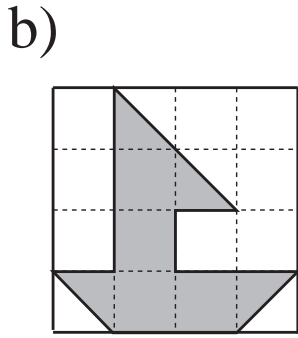
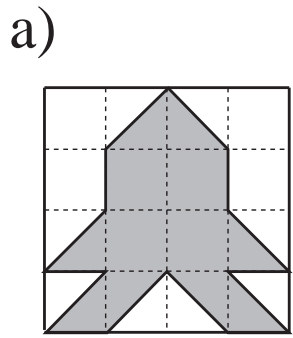

LP 78/4

 $\frac{1}{4}$
 $\frac{3}{4}$
 $\frac{1}{2}$

1 and a half

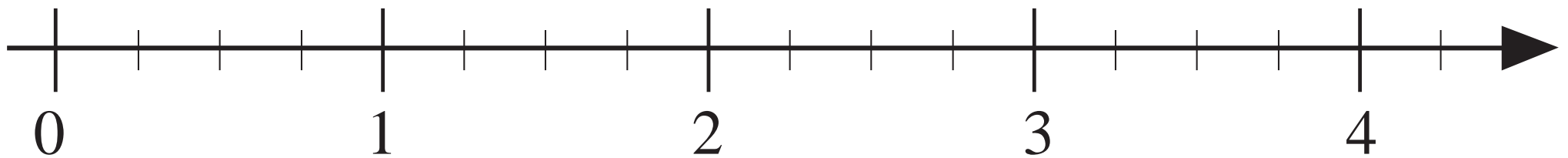
 $\frac{5}{4}$
 $\frac{8}{4}$
 $2\frac{3}{4}$

LP 78/6

a)

$$\frac{1}{2}$$

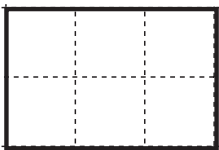

$$\frac{2}{2}$$

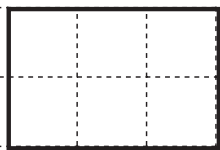

$$\frac{3}{2}$$

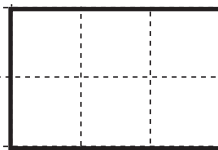

$$\frac{4}{2}$$

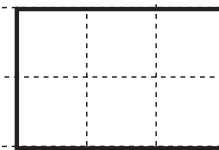

b)

$$\frac{1}{3}$$

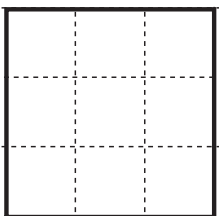

$$\frac{2}{3}$$

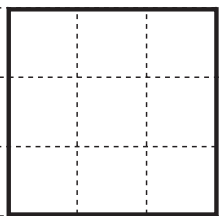

$$\frac{3}{3}$$

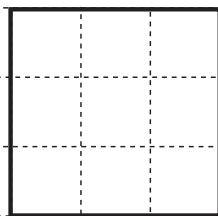

$$\frac{5}{3}$$

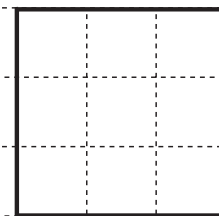

c)

$$\frac{2}{10}$$

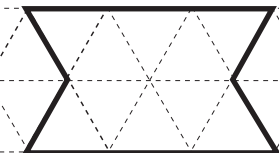

$$\frac{4}{10}$$

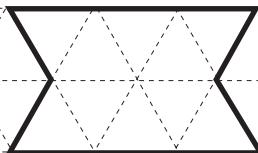

$$\frac{10}{10}$$

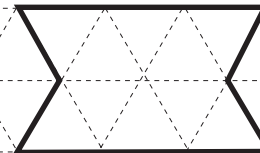

$$\frac{16}{10}$$

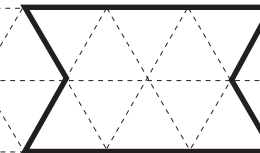

$$\frac{1}{2} \text{ litre} = \boxed{} \text{ cl} = \boxed{} \text{ ml}$$

$$\frac{1}{5} \text{ litre} = \boxed{} \text{ cl} = \boxed{} \text{ ml}$$

$$\frac{5}{2} \text{ litre} = \boxed{} \text{ cl} = \boxed{} \text{ ml}$$

$$\frac{1}{10} \text{ litre} = \boxed{} \text{ cl} = \boxed{} \text{ ml}$$

$$\frac{3}{10} \text{ litre} = \boxed{} \text{ cl} = \boxed{} \text{ ml}$$

$$\frac{1}{100} \text{ litre} = \boxed{} \text{ cl} = \boxed{} \text{ ml}$$

$$\frac{8}{100} \text{ litre} = \boxed{} \text{ cl} = \boxed{} \text{ ml}$$

$$\frac{70}{100} \text{ litre} = \boxed{} \text{ cl} = \boxed{} \text{ ml}$$

1 unit



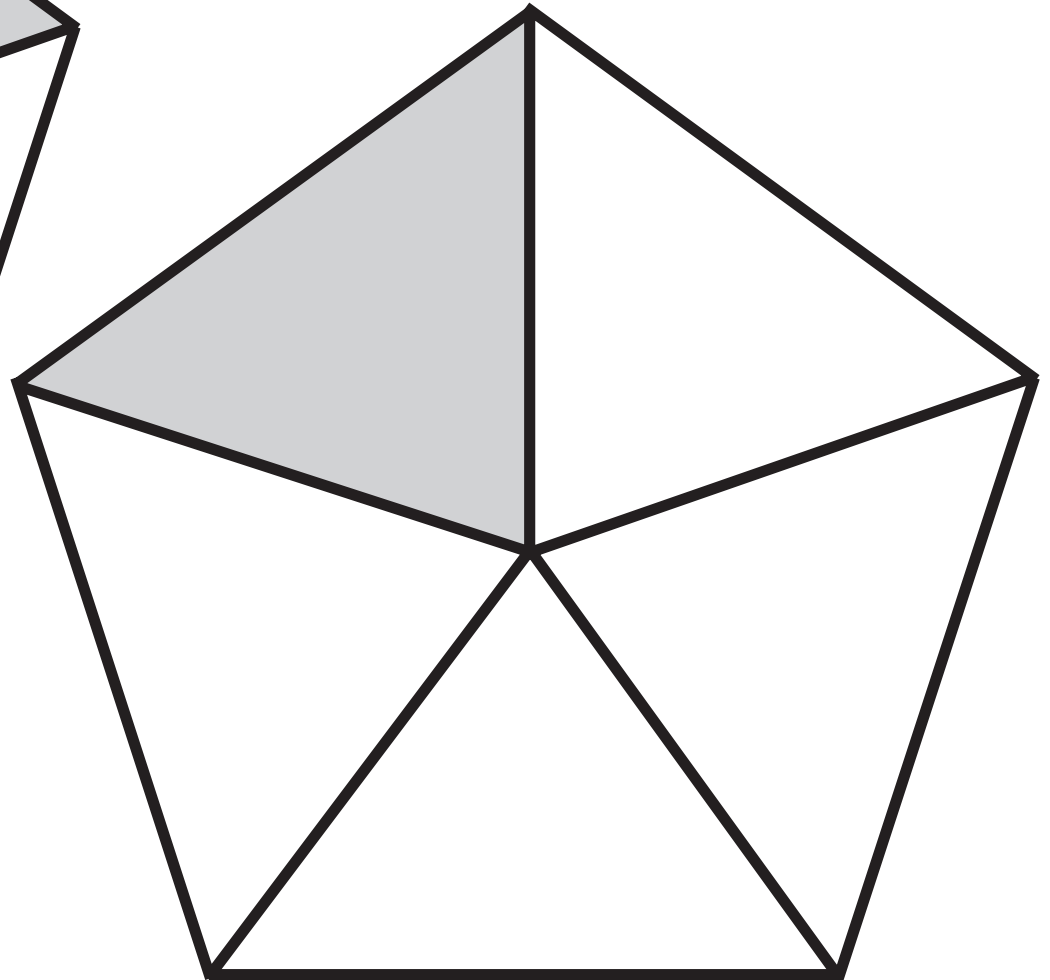
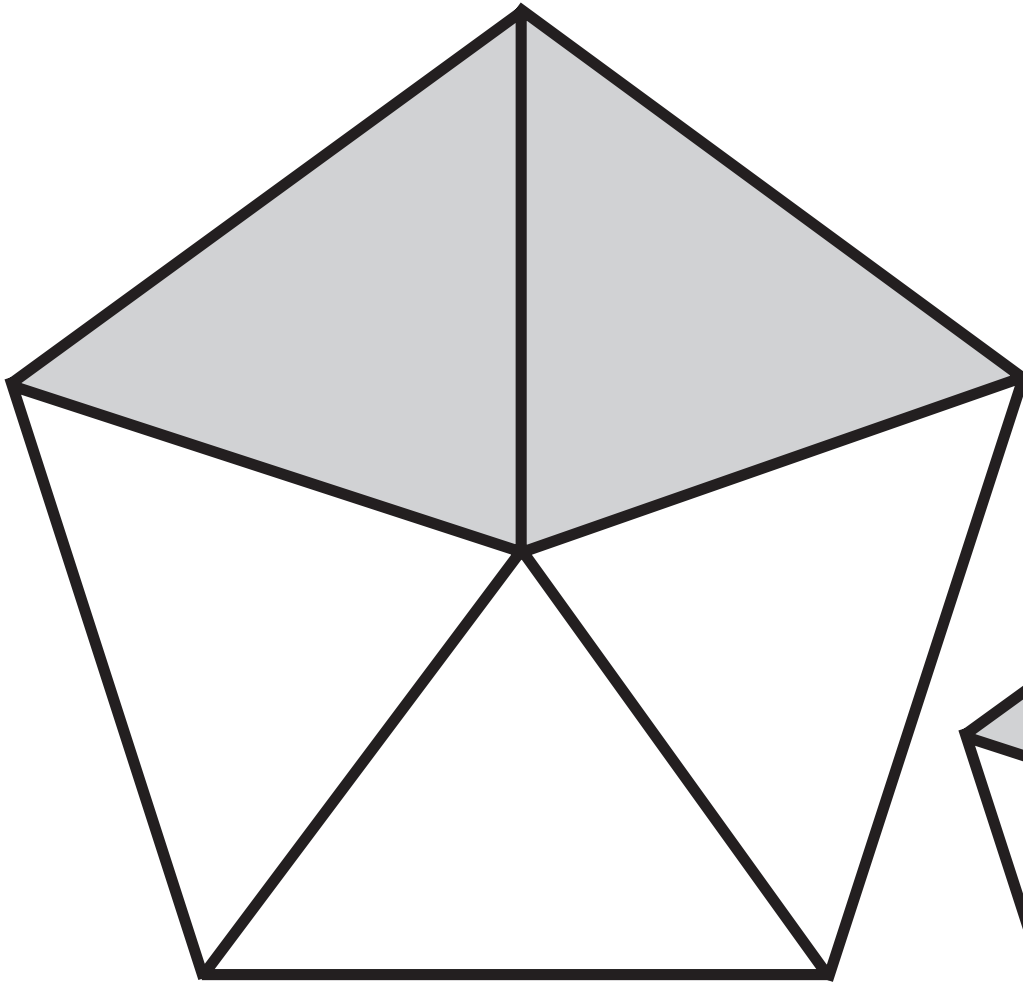

a)

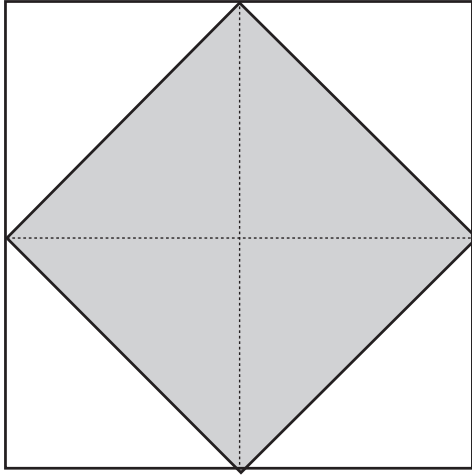

b)

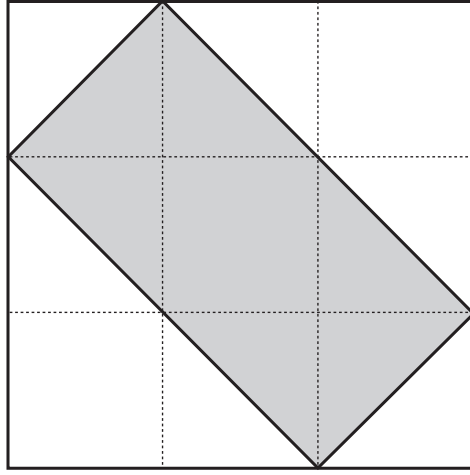

c)

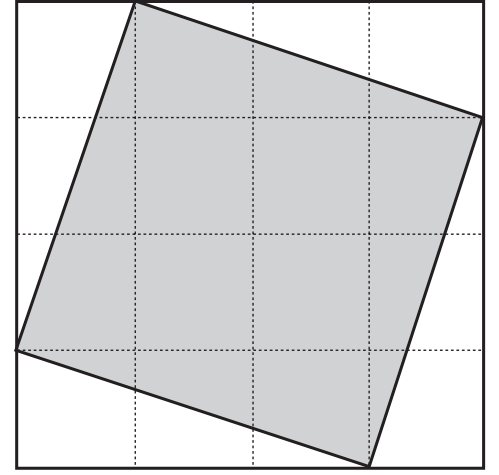

d)

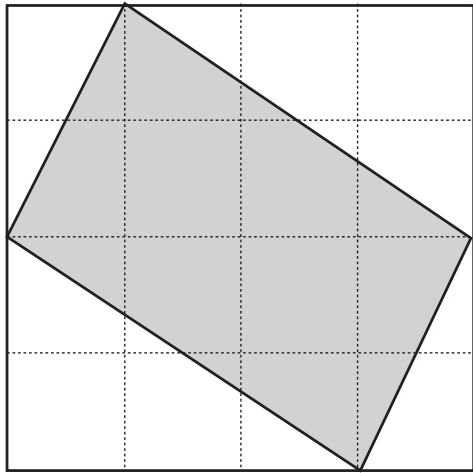

e)

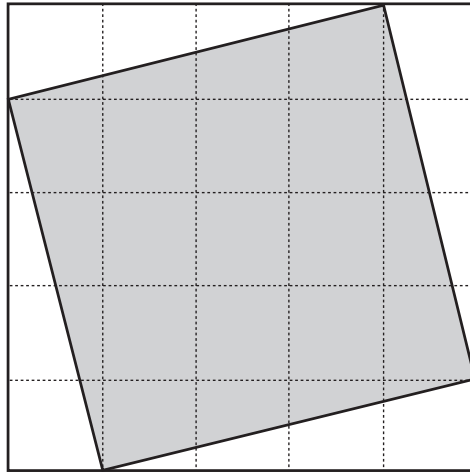

c)

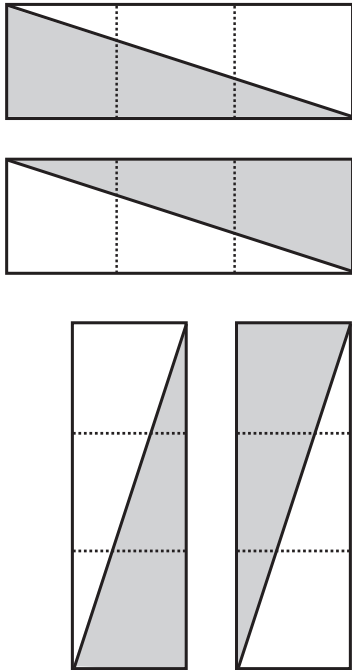

d)

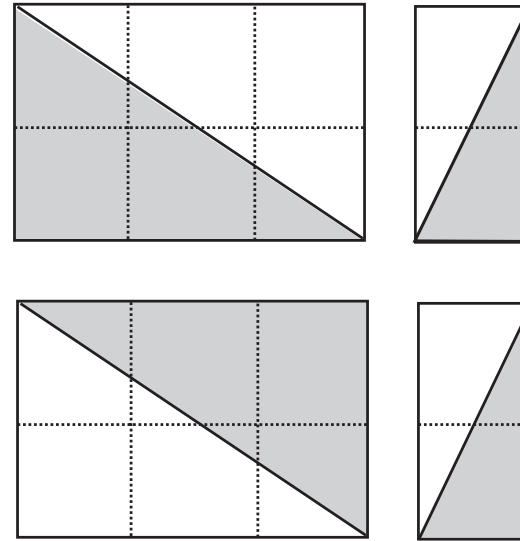

e)

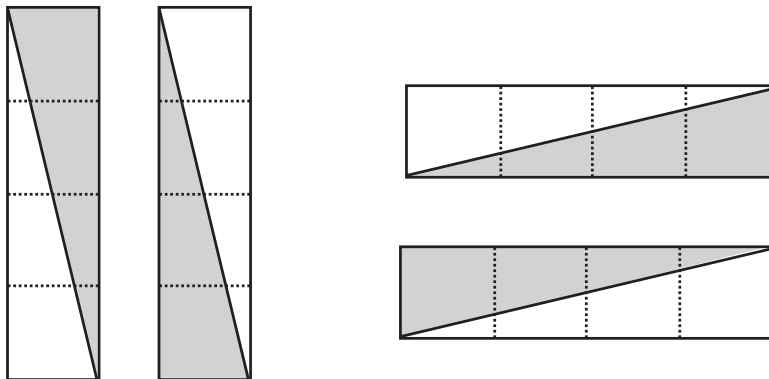

$$1 \text{ hour} = \boxed{} \text{ min.}$$

$$\text{a) } \frac{1}{4} \text{ hour} = \boxed{} \text{ min.}$$

$$\frac{3}{4} \text{ hour} = \boxed{} \text{ min.}$$

$$\text{b) } \frac{1}{2} \text{ hour} = \boxed{} \text{ min.}$$

$$\frac{2}{2} \text{ hour} = \boxed{} \text{ min.}$$

$$\text{c) } \frac{1}{3} \text{ hour} = \boxed{} \text{ min.}$$

$$\frac{4}{3} \text{ hour} = \boxed{} \text{ min.}$$

$$\text{d) } \frac{1}{6} \text{ hour} = \boxed{} \text{ min.}$$

$$\frac{9}{6} \text{ hour} = \boxed{} \text{ min.}$$

$$\text{e) } \frac{1}{5} \text{ hour} = \boxed{} \text{ min.}$$

$$\frac{3}{5} \text{ hour} = \boxed{} \text{ min.}$$

a)

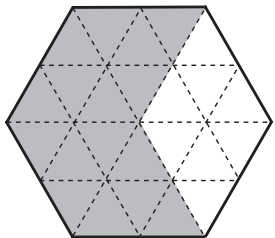

$$\square \frac{2}{3}$$

b)

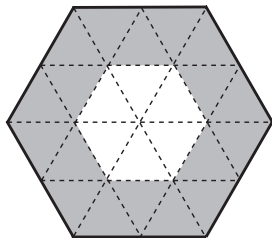

$$\square \frac{2}{3}$$

c)

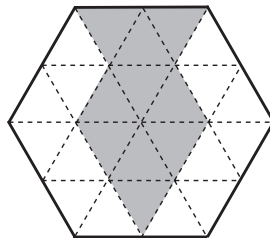

$$\square \frac{2}{3}$$

d)

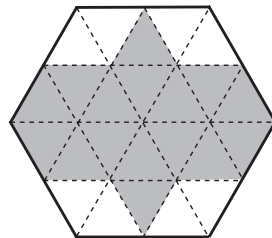

$$\square \frac{2}{3}$$

e)

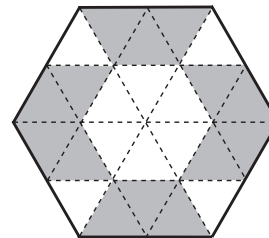

$$\square \frac{2}{3}$$

f)

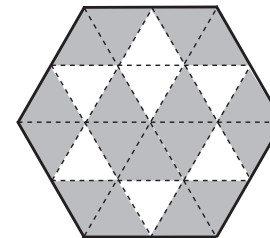

$$\square \frac{2}{3}$$

LP 79/4

a)

i)

$$\frac{3}{4}$$

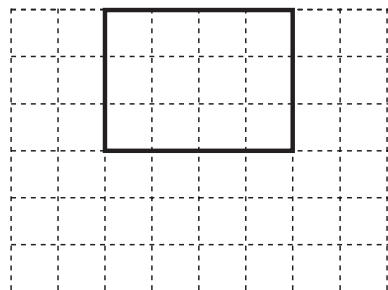

ii)

$$\frac{4}{3}$$

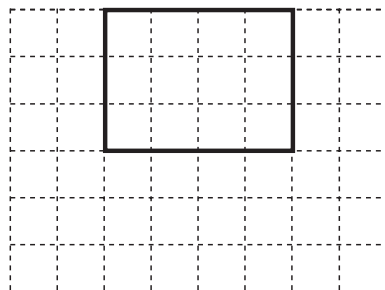

b)

i)

$$\frac{5}{4}$$

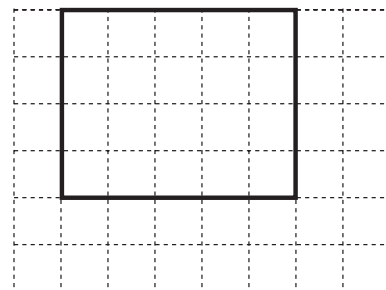

ii)

$$\frac{4}{5}$$

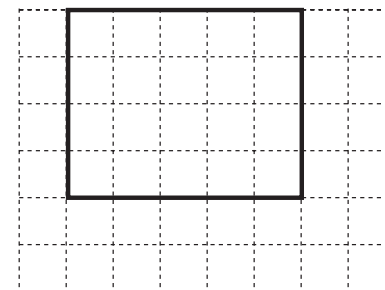

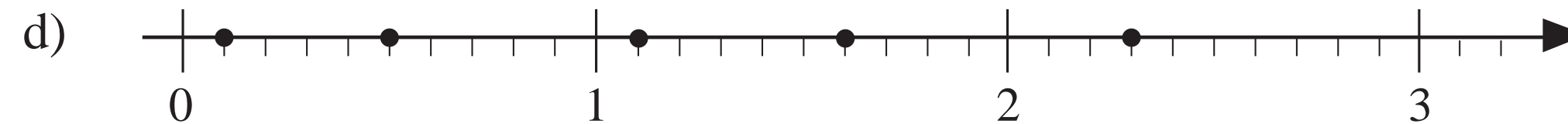
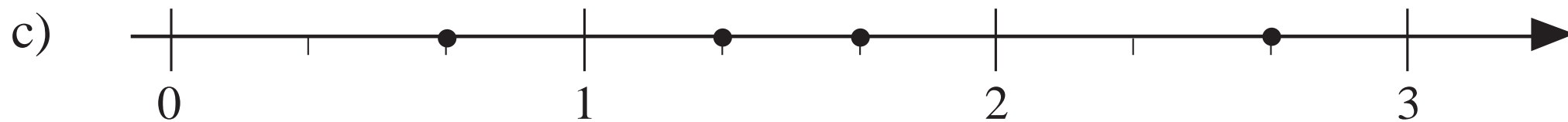
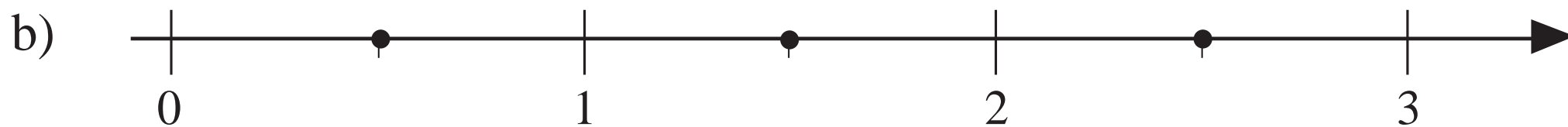

a) $\frac{1}{2}$ kg = g $\frac{3}{2}$ kg = g $\frac{1}{4}$ kg = g $\frac{1}{10}$ kg = g

$\frac{1}{5}$ kg = g $\frac{3}{5}$ kg = g $\frac{1}{100}$ kg = g $\frac{75}{100}$ kg = g

b) $\frac{1}{2}$ km = m $\frac{3}{2}$ km = m $\frac{3}{5}$ km = m $\frac{1}{10}$ km = m

$\frac{4}{10}$ km = m $\frac{3}{100}$ km = m $\frac{60}{100}$ km = m $\frac{523}{1000}$ km = m

$$\frac{1}{6}$$

$$\frac{1}{3}$$

$$\frac{1}{2}$$

$$\frac{5}{6}$$

$$\frac{9}{6}$$

$$1\frac{1}{2}$$

$$2\frac{1}{6}$$

$$2\frac{5}{6}$$

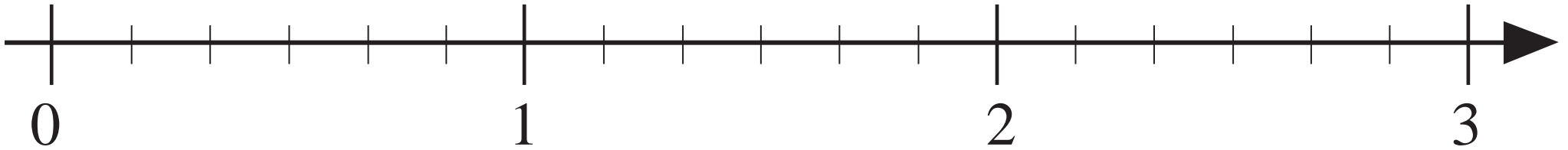

a) $\frac{1}{2} = \frac{\square}{4} = \frac{4}{\square} = \frac{\square}{6} = \frac{\square}{10} = \frac{10}{\square} = \frac{\square}{100} = \frac{\square}{\square}$

b) $\frac{1}{4} = \frac{\square}{16} = \frac{2}{\square} = \frac{\square}{20} = \frac{8}{\square} = \frac{25}{\square} = \frac{\square}{\square} = \frac{\square}{\square}$

c) $\frac{1}{3} = \frac{2}{\square} = \frac{\square}{12} = \frac{3}{\square} = \frac{\square}{15} = \frac{\square}{24} = \frac{\square}{30} = \frac{100}{\square} = \frac{\square}{\square}$

